

NS - ISA CARTESIAN SYSTEM LSA - ISA CARTESIAN SYSTEM

MULTI-SLIDER TYPE

www.intelligentactuator.com

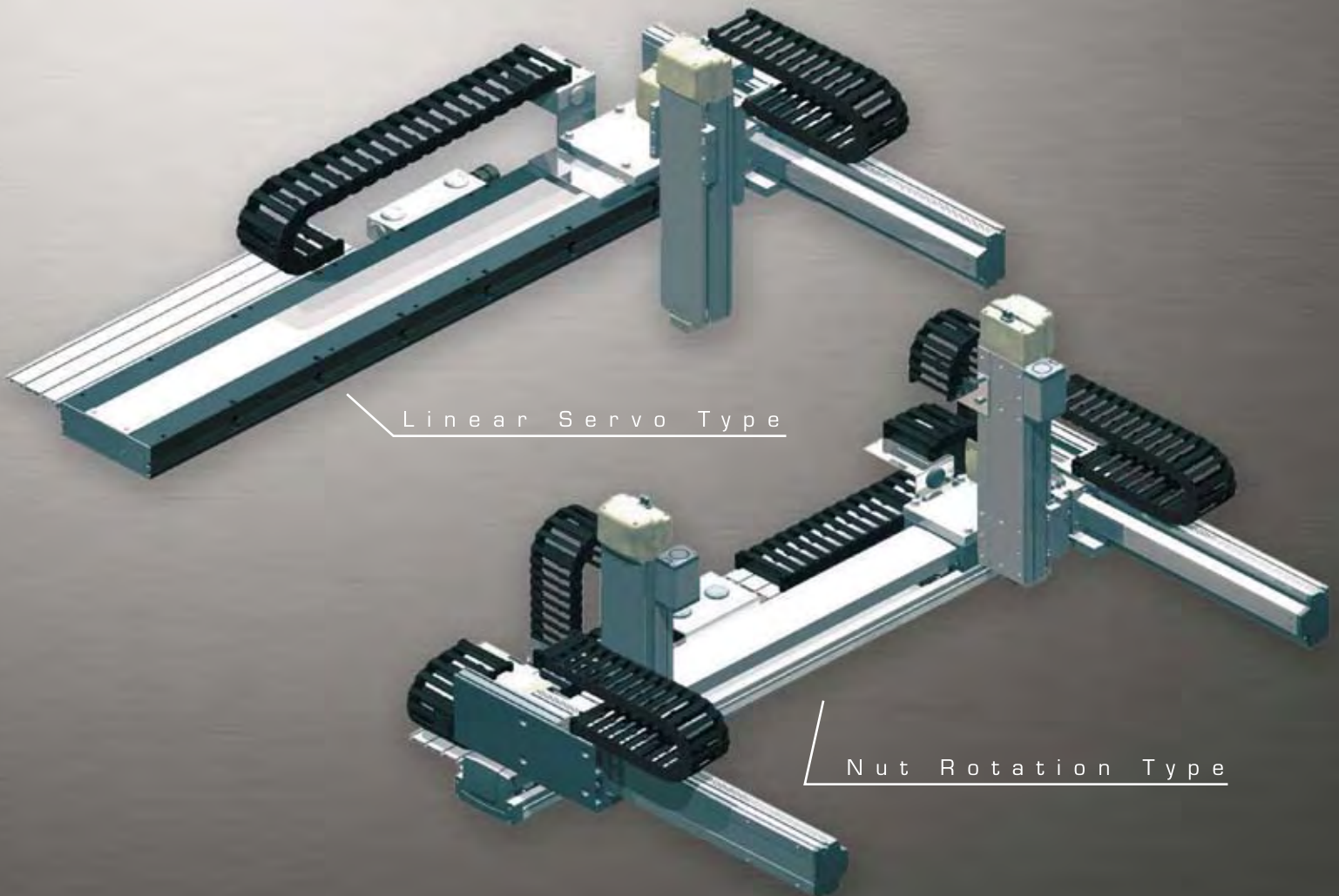

Introducing Two Multi-slider Type ^{*1} Cartesian Robots

*1 A multi-slider robot consists of two sliders installed in one axis, where both sliders can be operated independently.

Combined actuator units of nut rotation type offering excellent transfer capability

The built-in hollow motor in the slider turns the nut to move the actuator. Accordingly, heavy loads can be operated at high speed even at a long stroke. A desired combination can be selected from 2-axis, 3-axis, 4-axis (2 axes + 2 axes) and 6-axis (3 axes + 3 axes) configurations.

NS - ISA Cartesian System

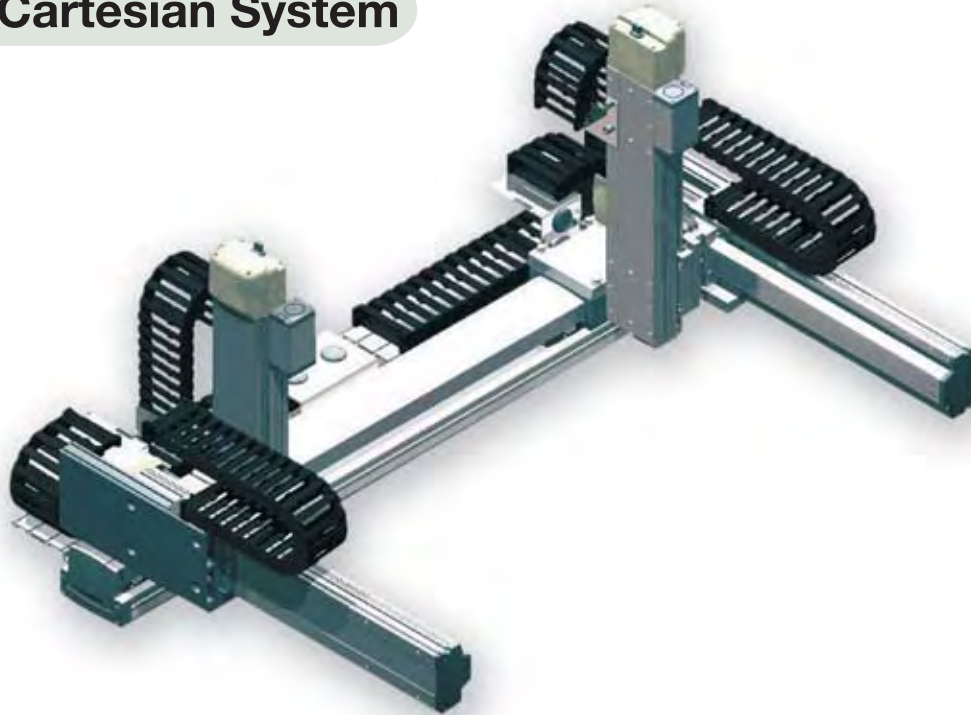

Combined actuator units of linear servo type offering excellent acceleration/deceleration performance

High-thrust linear servo actuators enable operations requiring a long stroke (up to 4,155 mm) and high acceleration/deceleration (rating: 1 G). A desired combination can be selected from 2-axis, 3-axis, 4-axis (2 axes + 2 axes) and 6-axis (3 axes + 3 axes) configurations.

LSA - ISA Cartesian System

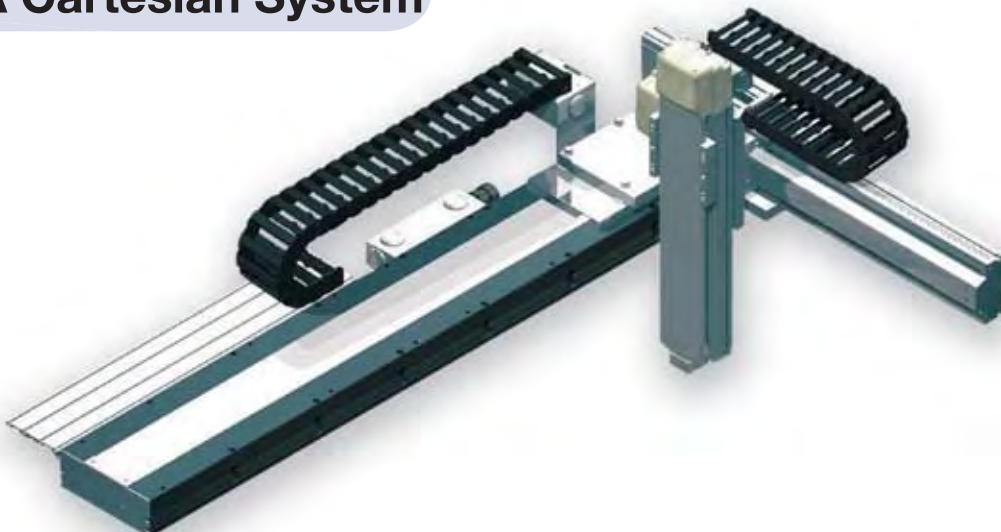
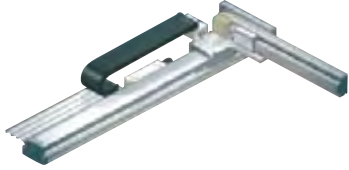



Table of Contents

	Z-axis	X-axis		Model	Page	
Nut rotation actuators	2-axis combo	Single-slider type	High-speed type	ICSPA2-B1N□H	P5	
			Medium-speed type	ICSPA2-B1N□M	P7	
		Long-stroke type (single slider)	High-speed type	ICSPA2-B2N□H	P9	
			Medium-speed type	ICSPA2-B2N□M	P11	
	3-axis combo	Z-axis base mount	Single-slider type	High-speed type	ICSPA3-B1N□HB3□	P13
				Medium-speed type	ICSPA3-B1N□MB3□	P15
			Long-stroke type (single slider)	High-speed type	ICSPA3-B2N□HB3□	P17
				Medium-speed type	ICSPA3-B2N□MB3□	P19
		Z-axis slider mount	Single-slider type	High-speed type	ICSPA3-B1N□HS3M	P21
				Medium-speed type	ICSPA3-B1N□MS3M	P23
			Long-stroke type (single slider)	High-speed type	ICSPA3-B2N□HS3M	P25
				Medium-speed type	ICSPA3-B2N□MS3M	P27
	4-axis combo (2 axes + 2 axes)		Multi-slider type	High-speed type	ICSPA4-B3N1H	P29
				Medium-speed type	ICSPA4-B3N1M	P31
6-axis combo (3 axes + 3 axes)	Z-axis base mount	Multi-slider type	High-speed type	ICSPA6-B3N1HB3□	P33	
			Medium-speed type	ICSPA6-B3N1MB3□	P35	
	Z-axis slider mount	Multi-slider type	High-speed type	ICSPA6-B3N1HS3M	P37	
			Medium-speed type	ICSPA6-B3N1MS3M	P39	
Linear servo actuators	2-axis combo	Single-slider type		ICSPA2-B1L□H	P41	
	3-axis combo	Z-axis base mount	Single-slider type		ICSPA3-B1L□HB3□	P43
		Z-axis slider mount	Single-slider type		ICSPA3-B1L□HS3M	P45
	4-axis combo (2 axes + 2 axes)		Multi-slider type		ICSPA4-B2L1H	P47
6-axis combo (3 axes + 3 axes)	Z-axis base mount	Multi-slider type		ICSPA6-B2L1HB3□	P49	
	Z-axis slider mount	Multi-slider type		ICSPA6-B2L1HS3M	P51	
Options	Actuator options				P53	
Controllers	2-axis controller			SSEL	P54	
	6-axis controller			XSEL	P64	



Cartesian Robots Using Nut Rotation Actuators / Large Linear Servos - Supporting Long Strokes, High-speed Moves and Multiple Sliders

NS (Nut Rotation Actuator) + ISA

Number of combined axes		2 axes				3 axes							
Z-axis installation method		-				Z-axis base mount							
Series		ICSPA2				ICSPA3							
Type		B1N□H	B1N□M	B2N□H	B2N□M	B1N□HB3H	B1N□HB3M	B1N□MB3H	B1N□MB3M	B2N□HB3H	B2N□HB3M	B2N□MB3H	B2N□MB3M
Exterior View													
Stroke (mm)	X-axis	500~2200		2250~3000		500~2200				2250~3000			
	Y-axis	200~700				200~700							
	Z-axis	-				100~500							
Speed (mm/s)	X-axis	2400	1300	2400	1300	2400		1300		2400		1300	
	Y-axis	1200	1200	1200	1200	1200				1200			
	Z-axis	-	-	-	-	1200	600	1200	600	1200	600	1200	600
Maximum Load Capacity (kg) ^{※1}		21.2	40.0	21.2	40.0	9.0	11.2	9.0	19.0	9.0	11.2	9.0	19.0
Page		P.5	P.7	P.9	P.11	P.13		P.15		P.17		P.19	

※1 : The load capacity changes according to the Y-axis stroke and Z-axis stroke. For details, check the page describing the type you are interested in.

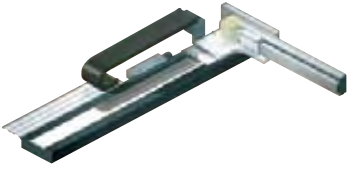
NS (Nut Rotation Actuator) + ISA

Number of combined axes		2 axes				3 axes			
Z-axis installation method		-				Z-axis base mount			
Series		ICSPA2				ICSPA3			
Type		B1L□H				B1L□HB3H		B1L□HB3M	
Exterior View									
Stroke (mm)	X-axis	1050~4155				1050~4155			
	Y-axis	200~400				200~400			
	Z-axis	-				100~400			
Speed (mm/s)	X-axis	2500				2500			
	Y-axis	1200				1200			
	Z-axis	-				1200		600	
Maximum Load Capacity (kg) ^{※1}		21.2				9.0		11.2	
Page		P.41				P.43			

※1 : The load capacity changes according to the Y-axis stroke and Z-axis stroke. For details, check the page describing the type you are interested in.

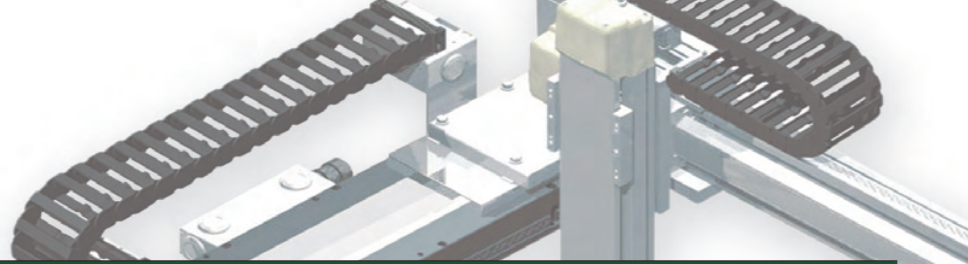

	3 axes				4 axes (2 axes + 2 axes)		6 axes (3 axes + 3 axes)					
	Z-axis slider mount				-		Z-axis base mount				Z-axis slider mount	
	ICSPA3				ICSPA4		ICSPA6					
	B1N□HS3M	B1N□MS3M	B2N□HS3M	B2N□MS3M	B3N1H	B3N1M	B3N1HB3H	B3N1HB3M	B3N1MB3H	B3N1MB3M	B3N1HS3M	B3N1MS3M
	500~2200		2250~3000		250~2250		250~2250					
	200~700				200~700		200~700					
	100~400				-		100~500				100~400	
	2400	1300	2400	1300	2400	1300	2400		1300		2400	1300
	1200	1200	1200	1200	1200	1200	1200		1200		1200	1200
	600	600	600	600	-	-	1200	600	1200	600	600	600
	11.5	13.0	11.5	13.0	21.2	40.0	9.0	11.2	9.0	19.0	11.5	13.0
	P.21	P.23	P.25	P.27	P.29	P.31	P.33		P.35		P.37	P.39

	3 axes				4 axes (2 axes + 2 axes)		6 axes (3 axes + 3 axes)					
	Z-axis slider mount				-		Z-axis base mount		Z-axis slider mount			
	ICSPA3				ICSPA4		ICSPA6					
	B1L□HS3M				B2L1H		B2L1HB3H	B2L1HB3M		B2L1HS3M		
	1050~4155				730~3835		730~3835					
	200~400				200~400		200~400					
	100~300				-		100~400				100~300	
	2500				2500		2500					
	1200				1200		1200					
	600				-		1200		600			
	11.5				21.2		9.0		11.2		11.5	
	P.45				P.47		P.49				P.51	

ICSPA2-B1N□H Cartesian robot / Nut rotation type + ISA (2 axes) XYB (Y-axis base mount) / X-axis high-speed type

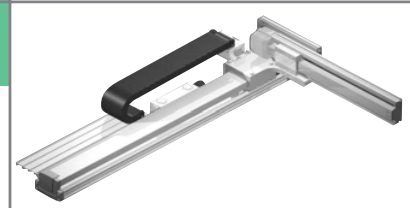

Model Designation ICSPA2 — B1N□H — □ — □ — □ — □ — □ — □ — T2 — □ — □

Series — Type — Encoder Type — X-axis stroke — Options — Y-axis stroke — Options — Applicable Controller — Cable Length — Y-axis cable wiring

ICSPA2 High-precision, 2-axis specification Refer to the "Model Details" table below.

A: Absolute specification 50:500 mm } Refer to the "Options" table } 20:200 mm } Refer to the "Options" table }
 I: Incremental specification 220:2200 mm below } 70:700 mm below }
 (50 mm increments) (50 mm increments)

T2: SCON SSEL XSEL-P/Q
 3L: 3 m 5L: 5 m
 □L: Specified length

CT: Cable track

Model Details

Encoder Type	XY combination direction (※)	Model
Absolute	1	ICSPA2-B1N1H-A-①AQRT-②AQ-T2-③-④
	2	ICSPA2-B1N2H-A-①AQRT-②AQ-T2-③-④
	3	ICSPA2-B1N3H-A-①AQRT-②AQ-T2-③-④
	4	ICSPA2-B1N4H-A-①AQRT-②AQ-T2-③-④
Incremental	1	ICSPA2-B1N1H-I-①AQRT-②AQ-T2-③-④
	2	ICSPA2-B1N2H-I-①AQRT-②AQ-T2-③-④
	3	ICSPA2-B1N3H-I-①AQRT-②AQ-T2-③-④
	4	ICSPA2-B1N4H-I-①AQRT-②AQ-T2-③-④

※ Refer to the figure below for the XY combination directions.
 ※ Refer to the table on the right for the details of ① to ④ in the model names shown above.

Explanation of Model Codes

No.	Description	Meaning
①	X-axis stroke (Note 1)	50 : 500mm } 220 : 2200mm
②	Y-axis stroke (Note 1)	20 : 200mm } 70 : 700mm
③	Cable Length (Note 2)	3L : 3m 5L : 5m □L : □m
④	Y-axis cable wiring	CT : Cable track

※ The above explains the details of ① to ④ in the model names shown to the left. X-axis.

XY Combination Direction

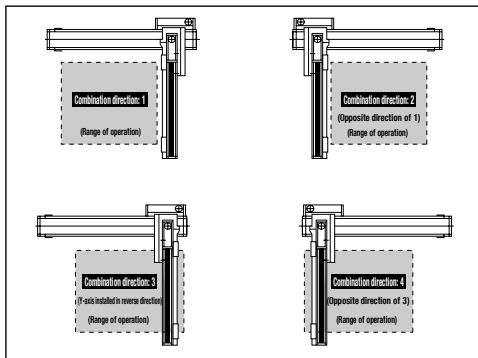

Component Axes

Component Axes	Model
X-axis	NS-LXMS-①-400-40-(Stroke)-T2-AQ-②-RT
Y-axis	ISPA-MYM-①-200-20-(Stroke)-T2-AQ

※Enter A (Absolute) or I (Incremental) into ① above.
 ※Enter NT1 or NT2 into ② above.
 NT1: Enter for cartesian combination direction 1 or 3
 NT2: Enter for cartesian combination direction 2 or 4
 (Note) Nut rotation type and large linear type require a cable track even for single-axis use, but when combined with cartesian robot, they use a different cable track. In this case, the specification will be for no cable track (NT1 or NT2).

Load Capacity by Acceleration (kg) (note 3)

		Y-axis stroke					
		200	300	400	500	600	700
Acceleration	0.3	21.2	20.3	19.4	18.4	17.5	16.6
	0.4	12.2	11.3	10.4	9.4	8.5	7.6
	0.5	7.7	6.8	5.9	4.9	4.0	3.1
	0.6	3.2	2.3	1.4	—	—	—
	0.7	—	—	—	—	—	—
	0.8	—	—	—	—	—	—
	0.9	—	—	—	—	—	—
	1.0	—	—	—	—	—	—

Options

Specify each applicable option code after the stroke of each axis.
 If you are selecting multiple options, specify them in an alphabetical order.

Name	Model	Reference page	Remarks
AQ seal	AQ	→P53	Standard feature
Brake	B	→P53	Limited to Y-axis
Creep sensor	C	→P53	
Home limit switch	L	→P53	
Opposite home specification	NM	→P53	Limited to Y-axis
Guide with ball retention mechanism	RT	→P53	Standard Feature on X-axis

Common Specifications

Drive method	Ball screw, rolled, C5 equivalent
Positioning repeatability	±0.01 mm
Lost motion	0.02 mm or less
Guide	Integrated with the base
Base	Material: Aluminum with white alumite treatment
X-axis motor output/lead	400 W/40 mm
Y-axis motor output/lead	200 W/20 mm

Maximum Speed by Stroke (mm/s)

	200	300	400	500	600	700	800~2200
X-axis	—	—	—	2400			
Y-axis	1200						—



(Note 1) Strokes are indicated in cm (centimeters) in model names.
 (Note 2) The cable length indicates the length from the X-axis connector box to the controller. Although the standard cable is 3 m or 5 m long, other lengths can be specified in units of meters. The maximum cable length is 20 m.
 (Note 3) The rated acceleration is 0.3 G. Although the actuator can operate at accelerations of up to 1 G, increasing the acceleration decreases the load capacity. (Contact IAI for load capacities at higher accelerations.)

ICSPA2-B1N□H

Dimensions

You can download CAD drawings from our website.

2D CAD

ME: Mechanical end
SE: Stroke end

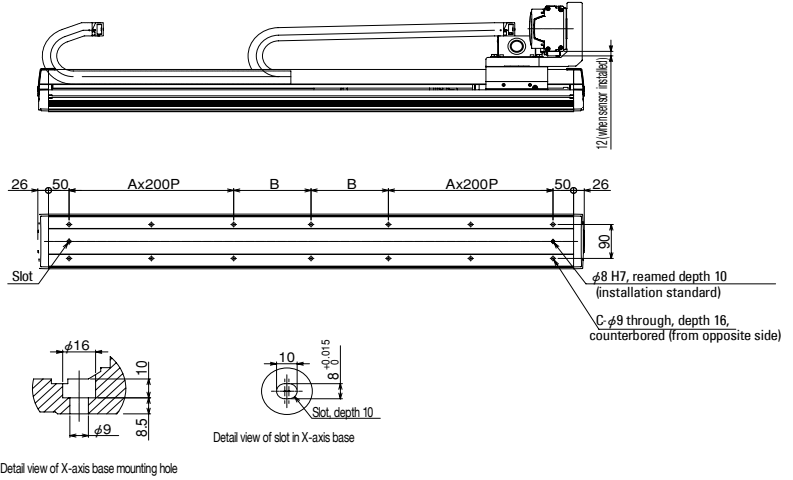
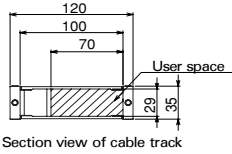
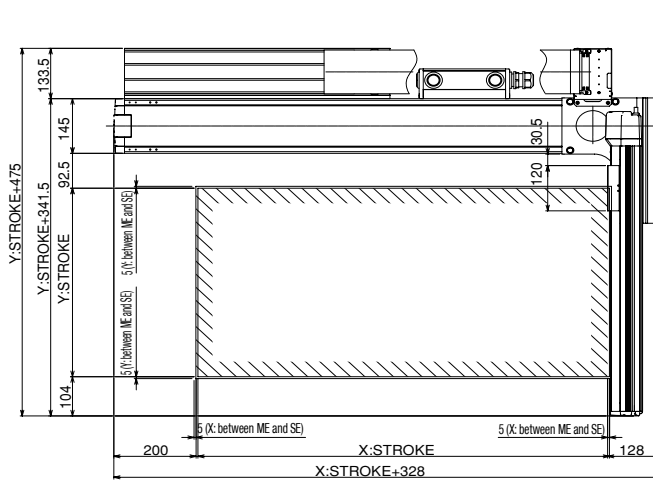
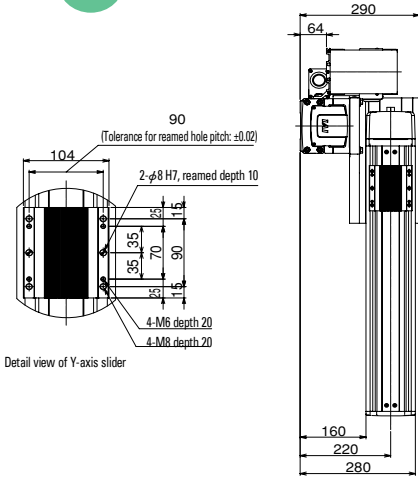

X stroke	500	550	600	650	700	750	800	850	900	950	1000	1050	1100	1150	1200	1250	1300	1350
A	1	1	1	1	1	1	1	2	2	2	2	2	2	2	2	2	3	3
B	138	163	188	213	238	263	288	313	338	363	388	413	438	463	488	513	538	563
C	10	10	10	10	10	10	10	14	14	14	14	14	14	14	14	14	18	18

X stroke	1400	1450	1500	1550	1600	1650	1700	1750	1800	1850	1900	1950	2000	2050	2100	2150	2200
A	3	3	3	3	3	3	4	4	4	4	4	4	4	4	5	5	5
B	188	213	238	263	288	313	338	363	388	413	438	463	488	513	538	563	588
C	18	18	18	18	18	18	22	22	22	22	22	22	22	22	26	26	26

ICSPA2-B1N□M

Cartesian robot / Nut rotation type + ISA (2 axes)
XY (Y-axis base mount) / X-axis medium-speed type

Model Designation ICSPA2 — B1N□M — □ — □ — □ — □ — T2 — □ — □

Series — Type — Encoder Type — X-axis stroke — Options — Y-axis stroke — Options — Applicable Controller — Cable Length — Y-axis cable wiring
 ICSPA2: High-precision, 2-axis specification Refer to the "Model Details" table below. A: Absolute specification I: Incremental specification 50:500 mm 220:2200 mm (50 mm increments) Refer to the "Options" table below 20:200 mm 70:700 mm (50 mm increments) Refer to the "Options" table below T2:SCON SSEL XSEL-P/Q 3L: 3 m 5L: 5 m □L: Specified length CT: Cable track

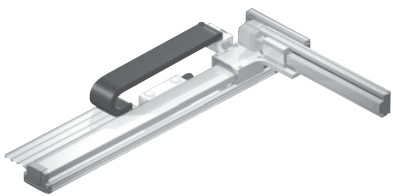

Model Details

Encoder Type	XY combination direction [°]	Model
Absolute	1	ICSPA2-B1N1M-A- ①AGRT- ②AQ-T2- ③-④
	2	ICSPA2-B1N2M-A- ①AGRT- ②AQ-T2- ③-④
	3	ICSPA2-B1N3M-A- ①AGRT- ②AQ-T2- ③-④
	4	ICSPA2-B1N4M-A- ①AGRT- ②AQ-T2- ③-④
Incremental	1	ICSPA2-B1N1M-I- ①AGRT- ②AQ-T2- ③-④
	2	ICSPA2-B1N2M-I- ①AGRT- ②AQ-T2- ③-④
	3	ICSPA2-B1N3M-I- ①AGRT- ②AQ-T2- ③-④
	4	ICSPA2-B1N4M-I- ①AGRT- ②AQ-T2- ③-④

*Refer to the figure below for the XY combination directions.
 *Refer to the table on the right for the details of ① to ④ in the model names shown above.

Explanation of Model Codes

No.	Description	Meaning
①	X-axis stroke (Note 1)	50 : 500mm } 220 : 2200mm
②	Y-axis stroke (Note 1)	20 : 200mm } 70 : 700mm
③	Cable Length (Note 2)	3L : 3m 5L : 5m □L : □m
④	Y-axis cable wiring	CT : Cable track

* The above explains the details of ① to ④ in the model names shown to the left. X-axis.

XY Combination Direction

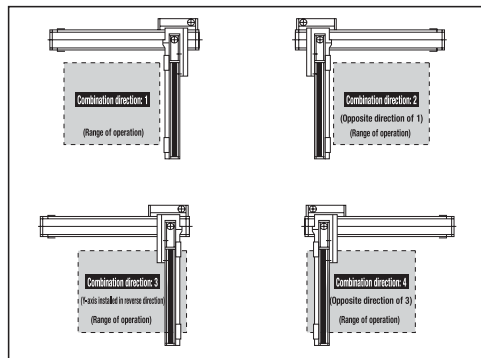

Component Axes

Component	Model
X-axis	NS-LXMS- ①-400-20 -(Stroke) -T2-AQ- ②-RT
Y-axis	ISPA-MYM- ①-200-20 -(Stroke) -T2-AQ

- Enter A (Absolute) or I (Incremental) into ① above.
 - Enter NT1 or NT2 into ② above.
 - NT1: Enter for cartesian combination direction 1 or 3
 - NT2: Enter for cartesian combination direction 2 or 4
- (Note) Nut rotation type and large linear type require a cable track even for single-axis use, but when combined with cartesian robot, they use a different cable track. In this case, the specification will be for no cable track (NT1 or NT2).

Load Capacity by Acceleration (kg) (note 3)

		Y-axis stroke					
		200	300	400	500	600	700
Acceleration	0.3	40.0	40.0	33.0	27.3	22.9	19.3
	0.4	30.0	30.0	30.0	27.3	22.9	19.3
	0.5	21.6	21.6	21.6	21.6	21.6	19.3
	0.6	18.0	18.0	18.0	18.0	17.5	16.6
	0.7	15.3	14.9	14.0	13.0	12.1	11.2
	0.8	12.2	11.3	10.4	9.4	8.5	7.6
	0.9	9.5	8.6	7.7	6.7	5.8	4.9
1.0	6.8	5.9	5.0	—	—	—	

Options

Specify each applicable option code after the stroke of each axis.
 If you are selecting multiple options, specify them in an alphabetical order.

Name	Model	Reference page	Remarks
AQ seal	AQ	P53	Standard feature
Brake	B	P53	Limited to Y-axis
Creep sensor	C	P53	
Home limit switch	L	P53	
Opposite home specification	NM	P53	Limited to Y-axis
Guide with ball retention mechanism	RT	P53	Standard Feature on X-axis

Common Specifications

Drive method	Ball screw, rolled, C5 equivalent
Positioning repeatability	±0.01 mm
Lost motion	0.02 mm or less
Guide	Integrated with the base
Base	Material: Aluminum with white alumite treatment
X-axis motor output/lead	400 W/20 mm
Y-axis motor output/lead	200 W/20 mm

Maximum Speed by Stroke (mm/s)

	200	300	400	500	600	700	800~2200
X-axis	—	—	—	1300			
Y-axis	1200						—

Caution

(Note 1) Strokes are indicated in cm (centimeters) in model names.
 (Note 2) The cable length indicates the length from the X-axis connector box to the controller. Although the standard cable is 3 m or 5 m long, other lengths can be specified in units of meters. The maximum cable length is 20 m.
 (Note 3) The rated acceleration is 0.3 G. Although the actuator can operate at accelerations of up to 1 G, increasing the acceleration decreases the load capacity. (Contact IAI for load capacities at higher accelerations.)

ICSPA2-B1N□M

Dimensions

You can download CAD drawings from our website.

2D CAD

ME: Mechanical end
SE: Stroke end

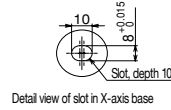
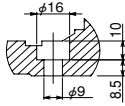
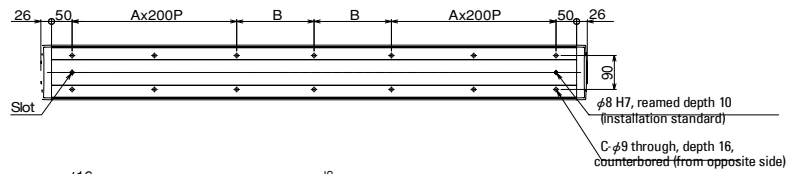
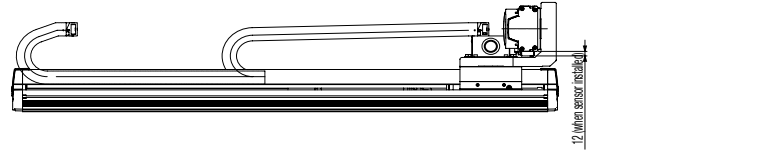
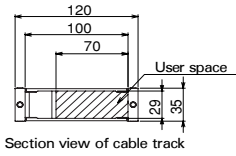
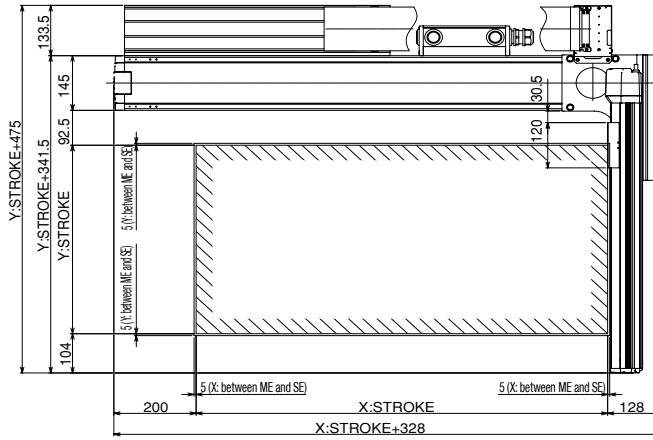
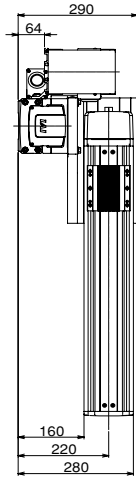
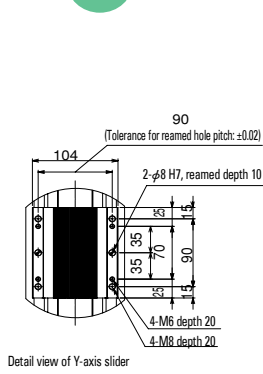

X stroke	500	550	600	650	700	750	800	850	900	950	1000	1050	1100	1150	1200	1250	1300	1350
A	1	1	1	1	1	1	1	2	2	2	2	2	2	2	2	2	3	3
B	138	163	188	213	238	263	288	313	338	363	388	413	438	463	488	513	538	563
C	10	10	10	10	10	10	10	14	14	14	14	14	14	14	14	14	18	18

X stroke	1400	1450	1500	1550	1600	1650	1700	1750	1800	1850	1900	1950	2000	2050	2100	2150	2200
A	3	3	3	3	3	3	4	4	4	4	4	4	4	4	5	5	5
B	188	213	238	263	288	313	338	363	388	413	438	463	488	513	538	563	588
C	18	18	18	18	18	18	22	22	22	22	22	22	22	22	26	26	26

ICSPA2-B2N□H

Cartesian robot / Nut rotation type + ISA (2 axes)
 XYB (Y-axis base mount) / X-axis long-stroke, high-speed type

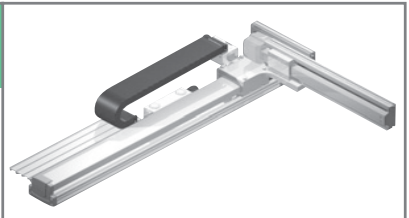

Model Designation **ICSPA2** — **B2N□H** — □ — □ — □ — □ — □ — **T2** — □ — □

Series	Type	Encoder Type	X-axis stroke	Options	Y-axis stroke	Options	Applicable Controller	Cable Length	Y-axis cable wiring
ICSPA2: High-precision, 2-axis specification	Refer to the "Model Details" table below.	A: Absolute specification I: Incremental specification	50:500 mm ↓ 300:3000 mm (50 mm increments)	Refer to the "Options" table ↓ 70:700 mm (50 mm increments)	20:200 mm ↓ 70:700 mm (50 mm increments)	Refer to the "Options" table	T2:SCON SSEL XSEL-P/Q	3L: 3 m 5L: 5 m □L: Specified length	CT: Cable track

Model Details

Encoder Type	XY combination direction (*)	Model
Absolute	1	ICSPA2-B2N1H-A- ①AQRT- ②AQ-T2- ③-④
	2	ICSPA2-B2N2H-A- ①AQRT- ②AQ-T2- ③-④
	3	ICSPA2-B2N3H-A- ①AQRT- ②AQ-T2- ③-④
	4	ICSPA2-B2N4H-A- ①AQRT- ②AQ-T2- ③-④
Incremental	1	ICSPA2-B2N1H-I- ①AQRT- ②AQ-T2- ③-④
	2	ICSPA2-B2N2H-I- ①AQRT- ②AQ-T2- ③-④
	3	ICSPA2-B2N3H-I- ①AQRT- ②AQ-T2- ③-④
	4	ICSPA2-B2N4H-I- ①AQRT- ②AQ-T2- ③-④

* Refer to the figure below for the XY combination directions.
 * Refer to the table on the right for the details of ① to ④ in the model names shown above.

Explanation of Model Codes

No.	Description	Meaning
①	X-axis stroke (Note 1)	225 : 2250mm 300 : 3000mm
②	Y-axis stroke (Note 1)	20 : 200mm 70 : 700mm
③	Cable Length (Note 2)	3L : 3m 5L : 5m □L : □m
④	Y-axis cable wiring	CT : Cable track

* The above explains the details of ① to ④ in the model names shown to the left. X-axis.

XY Combination Direction

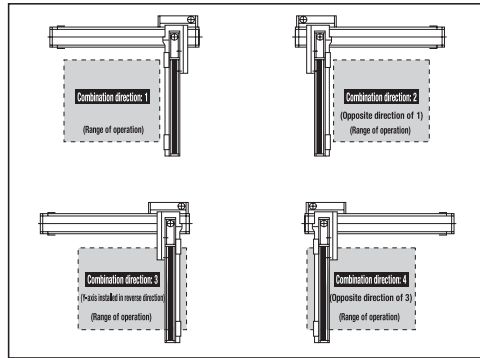

Component Axes

Component	Model
X-axis	NS-LXMS- ①-400-40 -(Stroke) -T2-AQ- ②-RT
Y-axis	ISPA-MYM- ①-200-20 -(Stroke) -T2-AQ

* Enter A (Absolute) or I (Incremental) into ① above.
 * Enter NT1 or NT2 into ② above.
 NT1: Enter for cartesian combination direction 1 or 3
 NT2: Enter for cartesian combination direction 2 or 4
 Note) Nut rotation type and large linear type require a cable track even for single-axis use, but when combined with cartesian robot, they use a different cable track. In this case, the specification will be for no cable track (NT1 or NT2).

Load Capacity by Acceleration (kg) (note 3)

		Y-axis stroke					
		200	300	400	500	600	700
Acceleration	0.3	21.2	20.3	19.4	18.4	17.5	16.6
	0.4	12.2	11.3	10.4	9.4	8.5	7.6
	0.5	7.7	6.8	5.9	4.9	4.0	3.1
	0.6	3.2	2.3	1.4	-	-	-
	0.7	-	-	-	-	-	-
	0.8	-	-	-	-	-	-
	0.9	-	-	-	-	-	-
	1.0	-	-	-	-	-	-

Options

Specify each applicable option code after the stroke of each axis.
 If you are selecting multiple options, specify them in an alphabetical order.

Name	Model	Reference page	Remarks
AQ seal	AQ	P53	Standard feature
Brake	B	P53	Limited to Y-axis
Creep sensor	C	P53	
Home limit switch	L	P53	
Opposite home specification	NM	P53	Limited to Y-axis
Guide with ball retention mechanism	RT	P53	Standard Feature on X-axis

Common Specifications

Drive method	Ball screw, rolled, C5 equivalent
Positioning repeatability	±0.01 mm
Lost motion	0.02 mm or less
Guide	Integrated with the base
Base	Material: Aluminum with white alumite treatment
X-axis motor output/lead	400 W/40 mm
Y-axis motor output/lead	200 W/20 mm

Maximum Speed by Stroke (mm/s)

	200	300	400	500	600	700	2250~3000
X-axis	-	-	-	-	-	-	2400
Y-axis	1200						-

Caution

(Note 1) Strokes are indicated in cm (centimeters) in model names.
 (Note 2) The cable length indicates the length from the X-axis connector box to the controller. Although the standard cable is 3 m or 5 m long, other lengths can be specified in units of meters. The maximum cable length is 20 m.
 (Note 3) The rated acceleration is 0.3 G. Although the Y-axis can operate at accelerations of up to 1 G, the acceleration is limited to 0.3 G for the X-axis. (Contact IAI for Y-axis load capacities at higher accelerations.)

ICSPA2-B2N□H

Dimensions

You can download CAD drawings from our website.

2D CAD

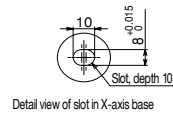
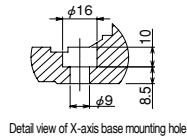
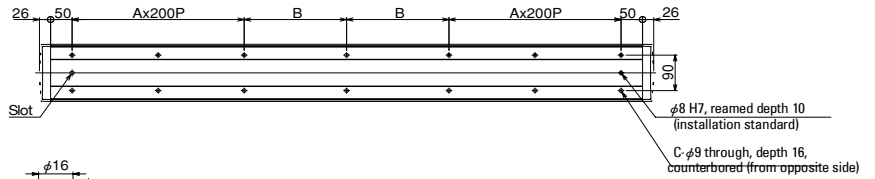
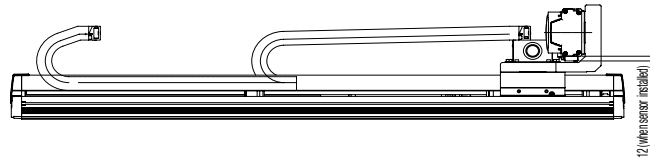
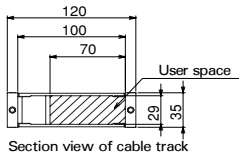
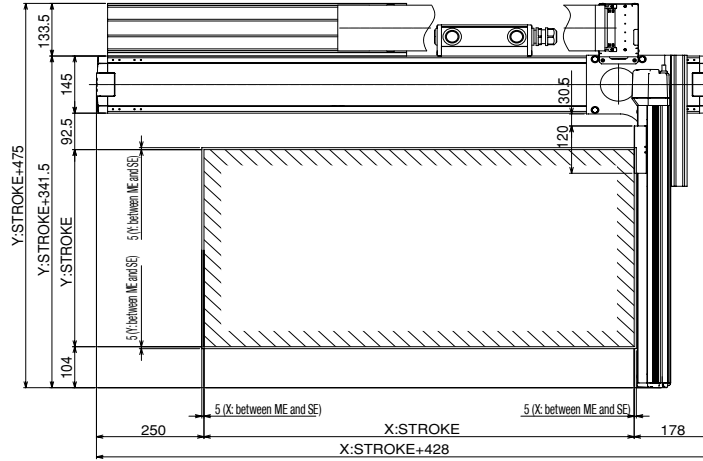
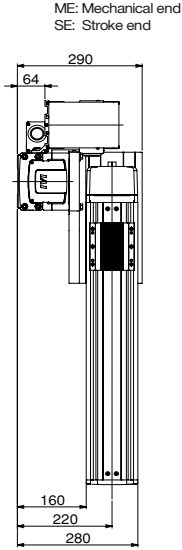
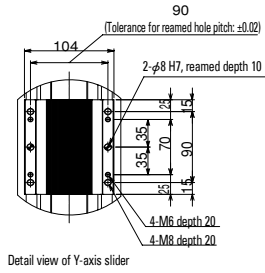

X stroke	2250	2300	2350	2400	2450	2500	2550	2600	2650	2700	2750	2800	2850	2900	2950	3000
A	5	5	5	6	6	6	6	6	6	6	6	7	7	7	7	7
B	263	288	313	138	163	188	213	238	263	288	313	138	163	188	213	238
C	26	26	26	30	30	30	30	30	30	30	30	34	34	34	34	34

ICSPA2-B2N □ M Cartesian robot / Nut rotation type + ISA (2 axes)

XYB (Y-axis base mount) / X-axis long-stroke, medium-speed type

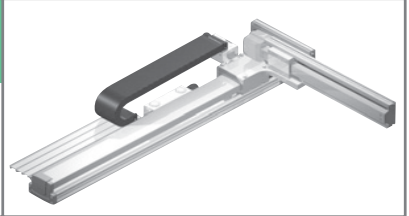

Model Designation **ICSPA2** — **B2N □ M** — □ — □ — □ — □ — □ — **T2** — □ — □

Series — Type — Encoder Type — X-axis stroke — Options — Y-axis stroke — Options — Applicable Controller — Cable Length — Y-axis cable wiring

ICSPA2: High-precision, 2-axis specification Refer to the "Model Details" table below. A: Absolute specification 50:500 mm Refer to the "Options" table 20:200 mm Refer to the "Options" table T2: SCON 3L: 3 m CT: Cable track
 I: Incremental specification 300:3000 mm (50 mm increments) below 70:700 mm (50 mm increments) below SSEL 5L: 5 m XSEL-P/Q □ L: Specified length

Model Details

Encoder Type	XY combination direction (*)	Model
Absolute	1	ICSPA2-B2N1M-A- ①AQRT- ②AQ-T2- ③-④
	2	ICSPA2-B2N2M-A- ①AQRT- ②AQ-T2- ③-④
	3	ICSPA2-B2N3M-A- ①AQRT- ②AQ-T2- ③-④
	4	ICSPA2-B2N4M-A- ①AQRT- ②AQ-T2- ③-④
Incremental	1	ICSPA2-B2N1M-I- ①AQRT- ②AQ-T2- ③-④
	2	ICSPA2-B2N2M-I- ①AQRT- ②AQ-T2- ③-④
	3	ICSPA2-B2N3M-I- ①AQRT- ②AQ-T2- ③-④
	4	ICSPA2-B2N4M-I- ①AQRT- ②AQ-T2- ③-④

* Refer to the figure below for the XY combination directions.
 * Refer to the table on the right for the details of ① to ④ in the model names shown above.

Explanation of Model Codes

No.	Description	Meaning
①	X-axis stroke (Note 1)	225 : 2250mm 300 : 3000mm
②	Y-axis stroke (Note 1)	20 : 200mm 70 : 700mm
③	Cable Length (Note 2)	3L : 3m 5L : 5m □ L : □m
④	Y-axis cable wiring	CT : Cable track

* The above explains the details of ① to ④ in the model names shown to the left. X-axis.

XY Combination Direction

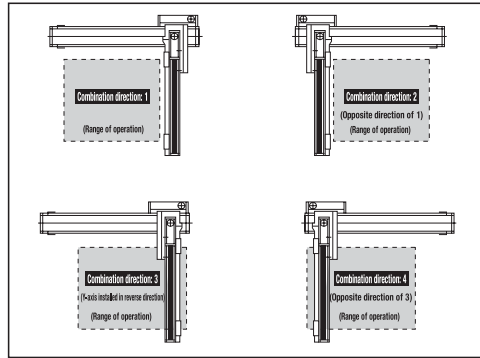

Component Axes

Component	Model
X-axis	NSLXMS- ①-400-20 -(Stroke) -T2-AQ- ②-RT
Y-axis	ISPA-MYM- ①-200-20 -(Stroke) -T2-AQ

* Enter A (Absolute) or I (Incremental) into ① above.
 * Enter NT1 or NT2 into ② above.
 NT1: Enter for cartesian combination direction 1 or 3
 NT2: Enter for cartesian combination direction 2 or 4
 Note) Nut rotation type and large linear type require a cable track even for single-axis use, but when combined with cartesian robot, they use a different cable track. In this case, the specification will be for no cable track (NT1 or NT2).

Load Capacity by Acceleration (kg) (note 3)

		Y-axis stroke					
		200	300	400	500	600	700
Acceleration	0.3	40.0	40.0	33.0	27.3	22.9	19.3
	0.4	30.0	30.0	30.0	27.3	22.9	19.3
	0.5	21.6	21.6	21.6	21.6	21.6	19.3
	0.6	18.0	18.0	18.0	18.0	17.5	16.6
	0.7	15.3	14.9	14.0	13.0	12.1	11.2
	0.8	12.2	11.3	10.4	9.4	8.5	7.6
	0.9	9.5	8.6	7.7	6.7	5.8	4.9
	1.0	6.8	5.9	5.0	—	—	—

Options

Specify each applicable option code after the stroke of each axis.
 If you are selecting multiple options, specify them in an alphabetical order.

Name	Model	Reference page	Remarks
AQ seal	AQ	P53	Standard feature
Brake	B	P53	Limited to Y-axis
Creep sensor	C	P53	
Home limit switch	L	P53	
Opposite home specification	NM	P53	Limited to Y-axis
Guide with ball retention mechanism	RT	P53	Standard Feature on X-axis

Common Specifications

Drive method	Ball screw, rolled, C5 equivalent
Positioning repeatability	±0.01 mm
Lost motion	0.02 mm or less
Guide	Integrated with the base
Base	Material: Aluminum with white alumite treatment
X-axis motor output/lead	400 W/20 mm
Y-axis motor output/lead	200 W/20 mm

Maximum Speed by Stroke (mm/s)

	200	300	400	500	600	700	2250~3000
X-axis	—	—	—	—	—	—	1300
Y-axis	1200						—

Caution

(Note 1) Strokes are indicated in cm (centimeters) in model names.
 (Note 2) The cable length indicates the length from the X-axis connector box to the controller. Although the standard cable is 3 m or 5 m long, other lengths can be specified in units of meters. The maximum cable length is 20 m.
 (Note 3) The rated acceleration is 0.3 G. Although the Y-axis can operate at accelerations of up to 1 G, the acceleration is limited to 0.3 G for the X-axis. (Contact IAI for Y-axis load capacities at higher accelerations.)

ICSPA2-B2N□M

Dimensions

You can download CAD drawings from our website.

2D CAD

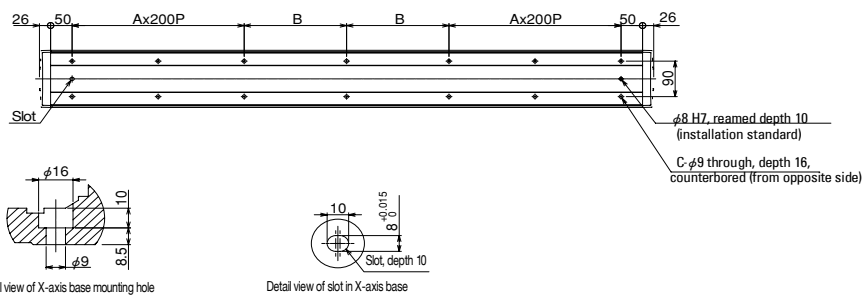
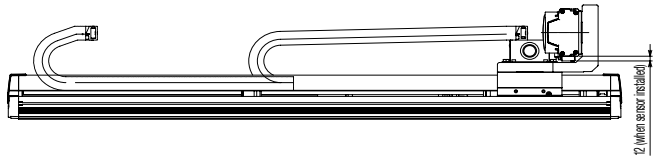
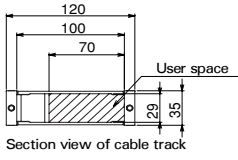
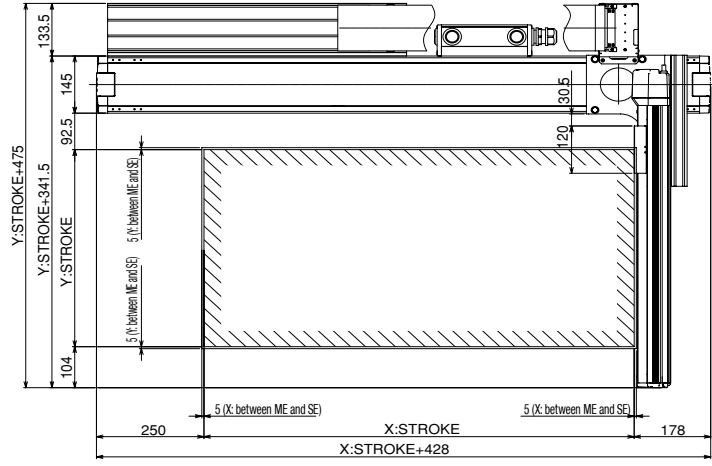
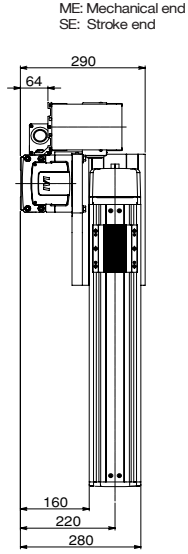
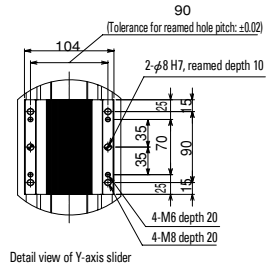

X stroke	2250	2300	2350	2400	2450	2500	2550	2600	2650	2700	2750	2800	2850	2900	2950	3000
A	5	5	5	6	6	6	6	6	6	6	6	7	7	7	7	7
B	263	288	313	138	163	188	213	238	263	288	313	138	163	188	213	238
C	26	26	26	30	30	30	30	30	30	30	30	34	34	34	34	34

ICSPA3-B1N□HB3□

Load Capacity (kg)

■ B1N□HB3H

		Y-axis Stroke					
		200	300	400	500	600	700
Z-axis Stroke		9.0			8.2	7.2	6.2
		9.0			8.3	7.2	6.2
		9.0	8.3	7.3	6.2	5.2	4.2
		8.2	7.3	6.3	5.2	4.2	3.2
		7.1	6.2	5.2	4.1	3.1	2.1

■ B1N□HB3M

		Y-axis Stroke					
		200	300	400	500	600	700
Z-axis Stroke		11.2	10.2	9.2	8.2	7.2	6.2
		10.2	9.3	8.3	7.2	6.2	5.2
		9.0	8.3	7.3	6.2	5.2	4.2
		8.2	7.3	6.3	5.2	4.2	3.2
		7.1	6.2	5.2	4.1	3.1	2.1

Maximum Speed by Stroke (mm/s)

■ B1N□HB3H

	Stroke								
	100	200	300	400	500	600	700	800~2200	
X-axis	-	-	-	-	2400				-
Y-axis	-	1200				-	-	-	-
Z-axis	1200			-	-	-	-	-	

■ B1N□HB3M

	Stroke								
	100	200	300	400	500	600	700	800~2200	
X-axis	-	-	-	-	2400				-
Y-axis	-	1200				-	-	-	-
Z-axis	600			-	-	-	-	-	

Dimensions

You can download CAD drawings from our website.

2D CAD

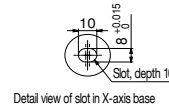
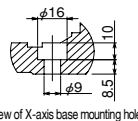
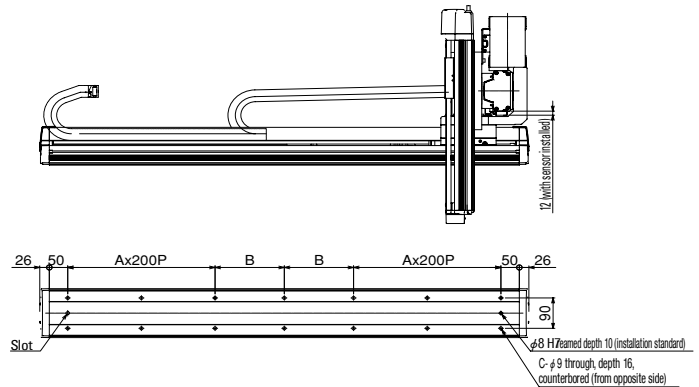
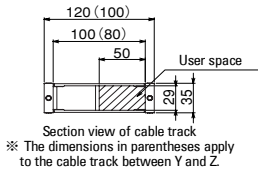
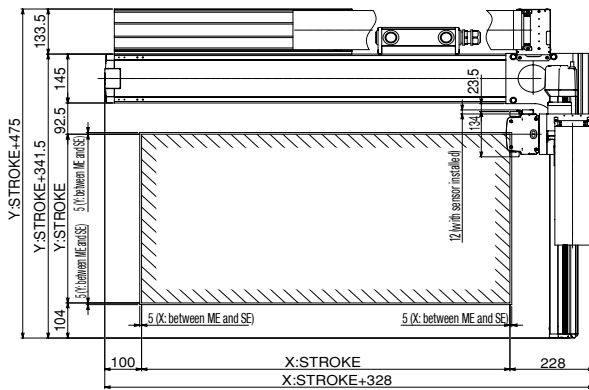
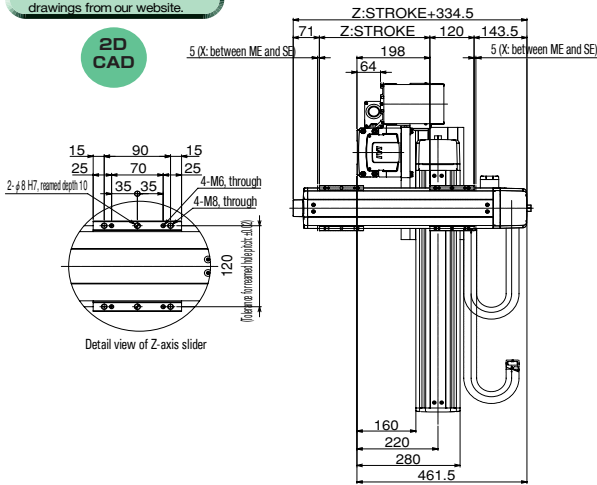

X Stroke	500	550	600	650	700	750	800	850	900	950	1000	1050	1100	1150	1200	1250	1300	1350
A	1	1	1	1	1	1	1	2	2	2	2	2	2	2	2	2	3	3
B	138	163	188	213	238	263	288	113	138	163	188	213	238	263	288	313	138	163
C	10	10	10	10	10	10	10	14	14	14	14	14	14	14	14	14	18	18

X Stroke	1400	1450	1500	1550	1600	1650	1700	1750	1800	1850	1900	1950	2000	2050	2100	2150	2200
A	3	3	3	3	3	3	4	4	4	4	4	4	4	4	5	5	5
B	188	213	238	263	288	313	138	163	188	213	238	263	288	313	138	163	188
C	18	18	18	18	18	18	22	22	22	22	22	22	22	22	26	26	26

ICSPA3-B1N MB3

Load Capacity (kg)

B1N MB3H

Z-axis Stroke	Y-axis Stroke					
	200	300	400	500	600	700
	9.0					8.9
	9.0					7.9
	9.0					6.9
	9.0					5.9
	9.0				8.5	4.8

B1N MB3M

Z-axis Stroke	Y-axis Stroke					
	200	300	400	500	600	700
	19.0			17.0	12.6	8.9
	19.0			16.1	11.6	7.9
	19.0			15.1	10.6	6.9
	19.0			14.1	9.6	5.9
	19.0		18.8	13.0	8.5	4.8

Maximum Speed by Stroke (mm/s)

B1N MB3H

Axis	Stroke							
	100	200	300	400	500	600	700	800~2200
X-axis	-	-	-	-	1300			-
Y-axis	-	1200				-	-	-
Z-axis	1200			-	-	-	-	-

B1N MB3M

Axis	Stroke							
	100	200	300	400	500	600	700	800~2200
X-axis	-	-	-	-	1300			-
Y-axis	-	1200				-	-	-
Z-axis	600			-	-	-	-	-

Dimensions

You can download CAD drawings from our website.

2D CAD

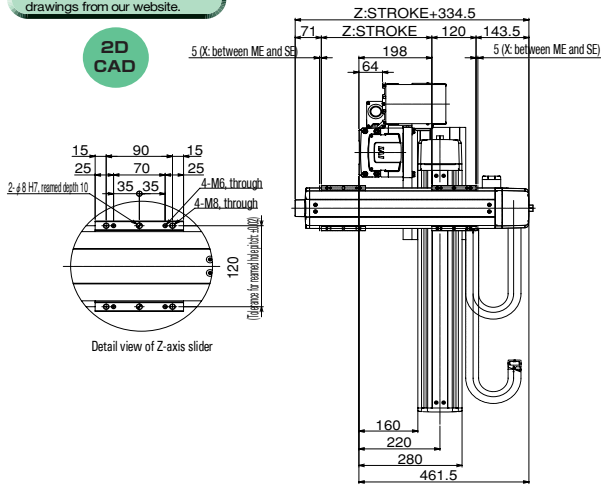

ME: Mechanical end
 SE: Stroke end

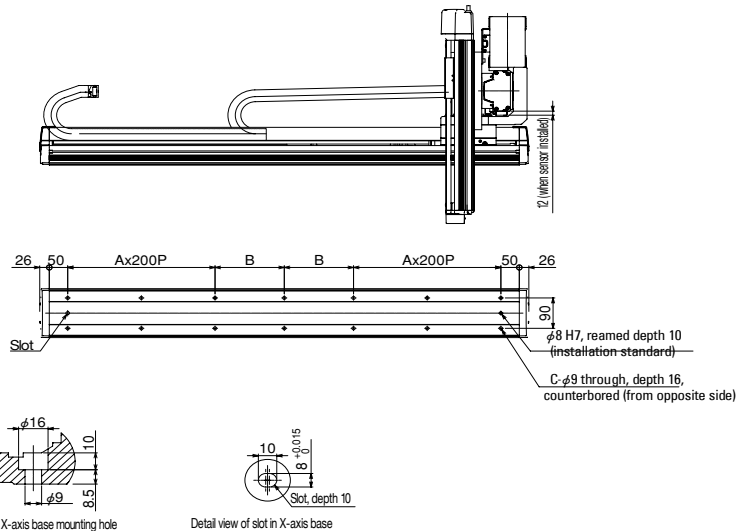
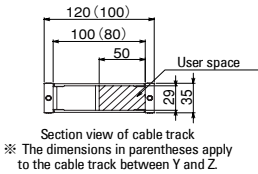
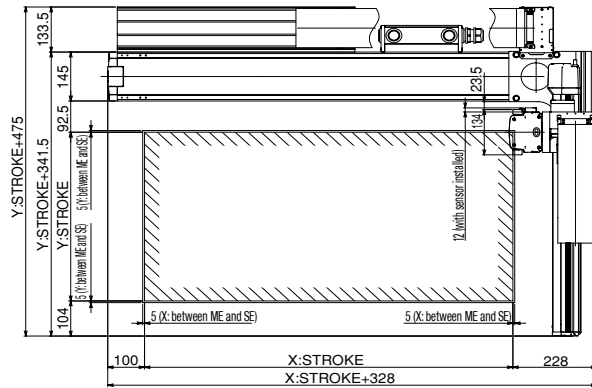

X Stroke	500	550	600	650	700	750	800	850	900	950	1000	1050	1100	1150	1200	1250	1300	1350
A	1	1	1	1	1	1	1	2	2	2	2	2	2	2	2	2	3	3
B	138	163	188	213	238	263	288	113	138	163	188	213	238	263	288	313	138	163
C	10	10	10	10	10	10	10	14	14	14	14	14	14	14	14	14	18	18

X Stroke	1400	1450	1500	1550	1600	1650	1700	1750	1800	1850	1900	1950	2000	2050	2100	2150	2200
A	3	3	3	3	3	3	4	4	4	4	4	4	4	4	5	5	5
B	188	213	238	263	288	313	138	163	188	213	238	263	288	313	138	163	188
C	18	18	18	18	18	18	22	22	22	22	22	22	22	22	26	26	26

ICSPA3-B2N HB3

Load Capacity (kg)

B2N HB3H

		Y-axis Stroke						
		200	300	400	500	600	700	
Z-axis Stroke		9.0				8.2	7.2	6.2
		9.0		8.3	7.2	6.2	5.2	
		9.0	8.3	7.3	6.2	5.2	4.2	
		8.2	7.3	6.3	5.2	4.2	3.2	
		7.1	6.2	5.2	4.1	3.1	2.1	

B2N HB3M

		Y-axis Stroke					
		200	300	400	500	600	700
Z-axis Stroke		11.2	10.2	9.2	8.2	7.2	6.2
		10.2	9.3	8.3	7.2	6.2	5.2
		9.0	8.3	7.3	6.2	5.2	4.2
		8.2	7.3	6.3	5.2	4.2	3.2
		7.1	6.2	5.2	4.1	3.1	2.1

Maximum Speed by Stroke (mm/s)

B2N HB3H

	Stroke							
	100	200	300	400	500	600	700	2250~3000
X-axis	-	-	-	-	-	-	-	2400
Y-axis	1200							-
Z-axis	1200			-	-	-	-	-

B2N HB3M

	Stroke							
	100	200	300	400	500	600	700	2250~3000
X-axis	-	-	-	-	-	-	-	2400
Y-axis	1200							-
Z-axis	600			-	-	-	-	-

Dimensions

You can download CAD drawings from our website.

2D CAD

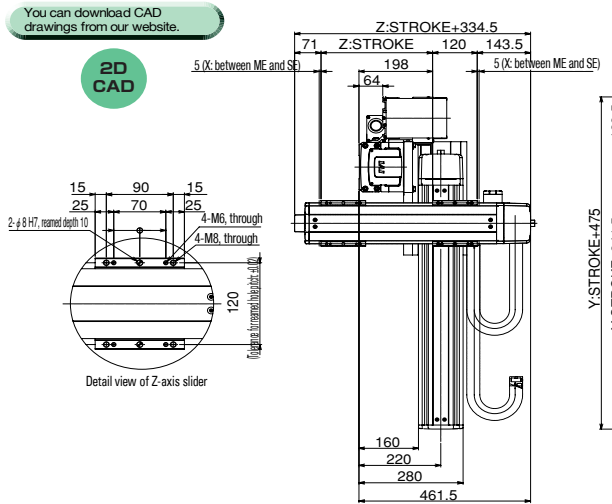

ME: Mechanical end
 SE: Stroke end

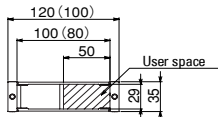
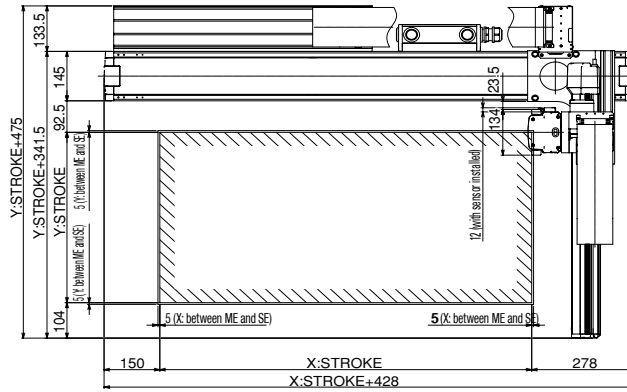

Section view of cable track
 ※ The dimensions in parentheses apply to the cable track between Y and Z.

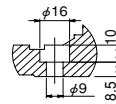
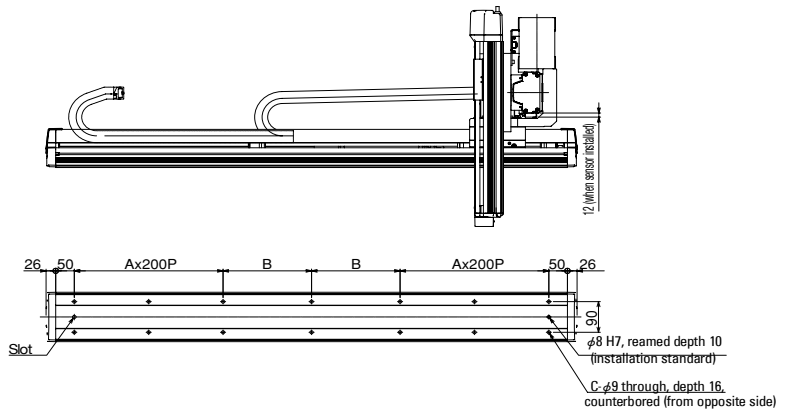

Detail view of X-axis base mounting hole

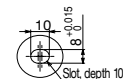

Detail view of slot in X-axis base

X Stroke	2250	2300	2350	2400	2450	2500	2550	2600	2650	2700	2750	2800	2850	2900	2950	3000
A	5	5	5	6	6	6	6	6	6	6	6	7	7	7	7	7
B	263	288	313	138	163	188	213	238	263	288	313	138	163	188	213	238
C	26	26	26	30	30	30	30	30	30	30	30	34	34	34	34	34

ICSPA3-B2N MB3

Load Capacity (kg)

B2N MB3H

Z-axis Stroke	Y-axis Stroke					
	200	300	400	500	600	700
Z-axis Stroke	9.0					8.9
	9.0					7.9
	9.0					6.9
	9.0					5.9
9.0					8.5	4.8

B2N MB3M

Z-axis Stroke	Y-axis Stroke						
	200	300	400	500	600	700	
Z-axis Stroke	19.0				17.0	12.6	8.9
	19.0				16.1	11.6	7.9
	19.0				15.1	10.6	6.9
	19.0				14.1	9.6	5.9
19.0				18.8	13.0	8.5	4.8

Maximum Speed by Stroke (mm/s)

B2N MB3H

Axis	Stroke								
	100	200	300	400	500	600	700	2250~3000	
X-axis	-	-	-	-	-	-	-	-	1300
Y-axis	1200							-	-
Z-axis	1200			-	-	-	-	-	-

B2N MB3M

Axis	Stroke								
	100	200	300	400	500	600	700	2250~3000	
X-axis	-	-	-	-	-	-	-	-	1300
Y-axis	1200							-	-
Z-axis	600			-	-	-	-	-	-

Dimensions

You can download CAD drawings from our website.

2D CAD

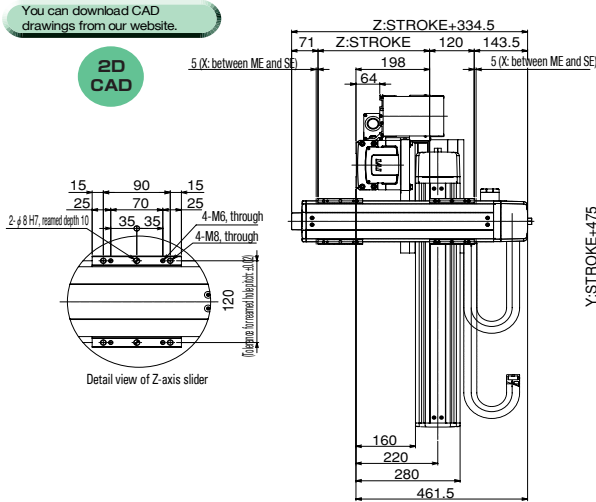

ME: Mechanical end
SE: Stroke end

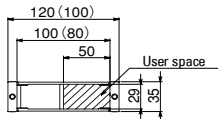
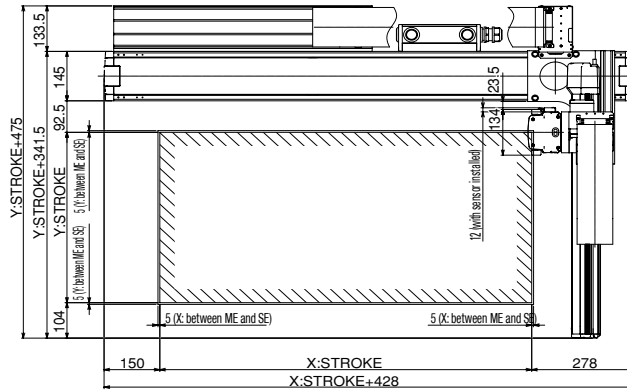

Section view of cable track
※ The dimensions in parentheses apply to the cable track between Y and Z.

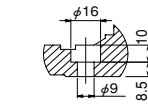
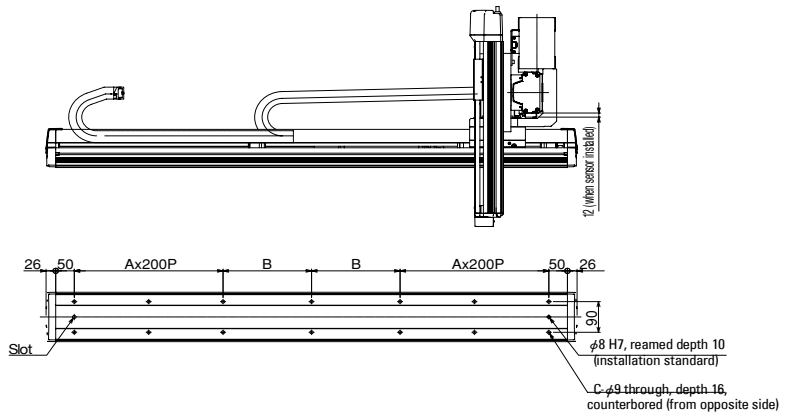

Detail view of X-axis base mounting hole

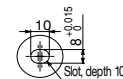

Detail view of slot in X-axis base

X Stroke	2250	2300	2350	2400	2450	2500	2550	2600	2650	2700	2750	2800	2850	2900	2950	3000
A	5	5	5	6	6	6	6	6	6	6	6	7	7	7	7	7
B	263	288	313	138	163	188	213	238	263	288	313	138	163	188	213	238
C	26	26	26	30	30	30	30	30	30	30	30	34	34	34	34	34

ICSPA3-B1N□HS3M

Load Capacity (kg)

■ B1N □ HS3M

		Y-axis Stroke					
		200	300	400	500	600	700
Z-axis Stroke	100	11.5	10.5	9.5	8.4	7.5	6.5
	~200	10.5	9.5	8.5	7.4	6.5	5.5
	~300	9.5	8.5	7.5	6.4	5.5	4.5
	~400	8.4	7.4	6.5	5.4	4.4	3.4

Maximum Speed by Stroke (mm/s)

■ B1N □ HS3M

	Stroke								
	100	200	300	400	500	600	700	800~2200	
X-axis	-	-	-	-	2400				-
Y-axis	1200								-
Z-axis	600		-	-	-	-	-	-	

Dimensions

You can download CAD drawings from our website.

2D CAD

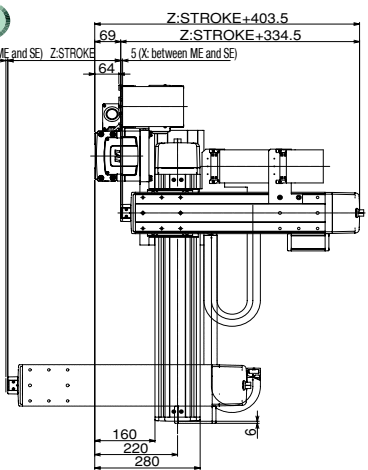
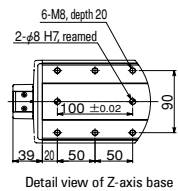

ME: Mechanical end
SE: Stroke end

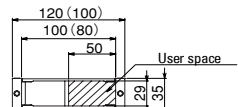
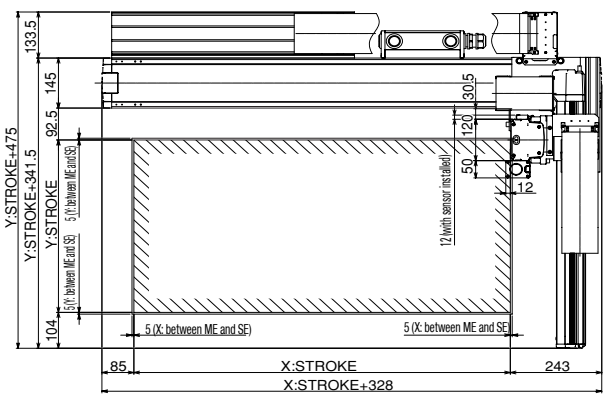

Section view of cable track
※ The dimensions in parentheses apply to the cable track between Y and Z

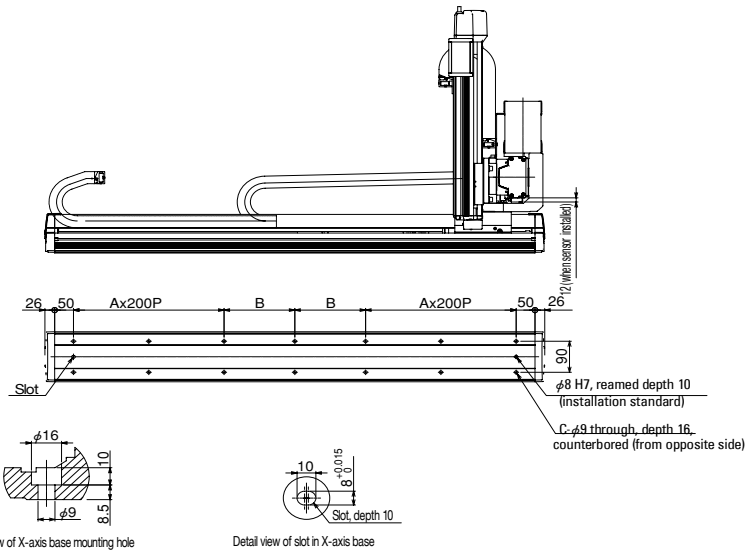

X Stroke	500	550	600	650	700	750	800	850	900	950	1000	1050	1100	1150	1200	1250	1300	1350
A	1	1	1	1	1	1	1	2	2	2	2	2	2	2	2	2	3	3
B	138	163	188	213	238	263	288	113	138	163	188	213	238	263	288	313	138	163
C	10	10	10	10	10	10	10	14	14	14	14	14	14	14	14	14	18	18

X Stroke	1400	1450	1500	1550	1600	1650	1700	1750	1800	1850	1900	1950	2000	2050	2100	2150	2200
A	3	3	3	3	3	3	3	4	4	4	4	4	4	4	5	5	5
B	188	213	238	263	288	313	138	163	188	213	238	263	288	313	138	163	188
C	18	18	18	18	18	18	22	22	22	22	22	22	22	22	26	26	26

ICSPA3-B1N□MS3M

Load Capacity (kg)

■ B1N □ MS3M

		Y-axis Stroke					
		200	300	400	500	600	700
Z-axis Stroke		13.0					9.1
		11.7					8.1
		10.7					7.1
		9.7					6.1

Maximum Speed by Stroke (mm/s)

■ B1N □ MS3M

		Stroke							
		100	200	300	400	500	600	700	800~2200
X-axis	-	-	-	-	1300				-
Y-axis	-	1200							-
Z-axis	600		-	-	-	-	-	-	

Dimensions

You can download CAD drawings from our website.

2D CAD

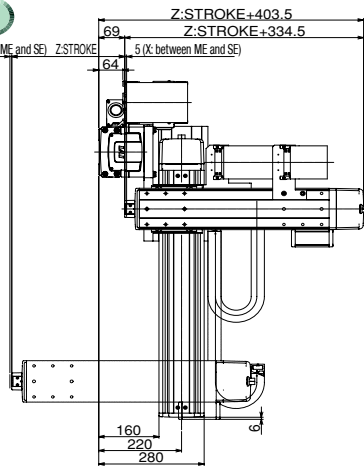
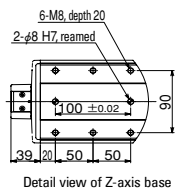

ME: Mechanical end
SE: Stroke end

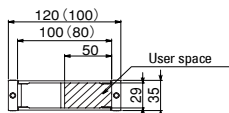
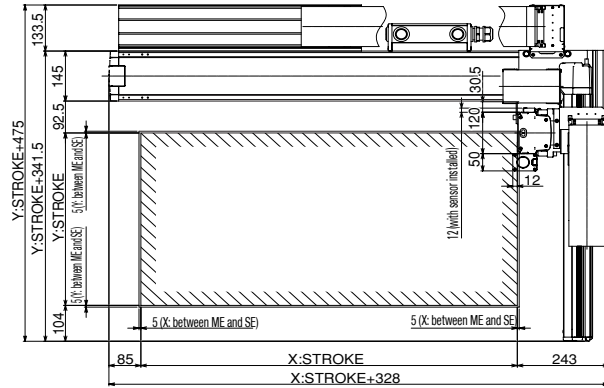

Section view of cable track
※ The dimensions in parentheses apply to the cable track between Y and Z.

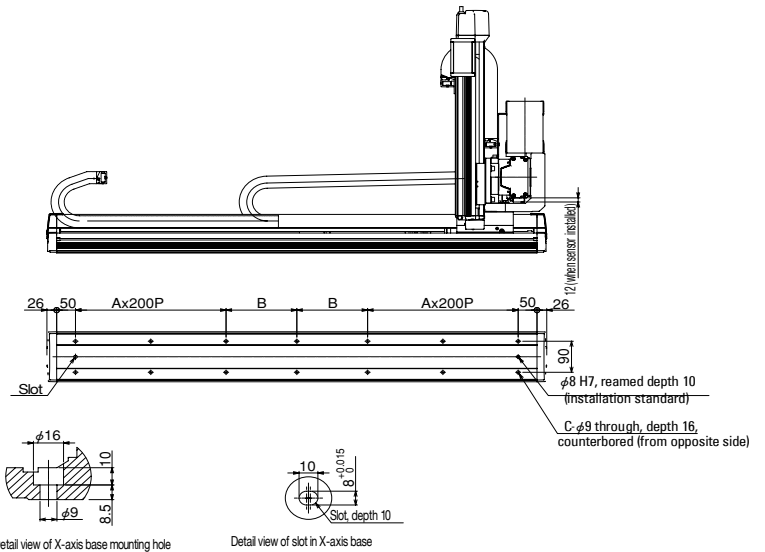

X Stroke	500	550	600	650	700	750	800	850	900	950	1000	1050	1100	1150	1200	1250	1300	1350
A	1	1	1	1	1	1	1	2	2	2	2	2	2	2	2	2	3	3
B	138	163	188	213	238	263	288	113	138	163	188	213	238	263	288	313	138	163
C	10	10	10	10	10	10	10	14	14	14	14	14	14	14	14	14	18	18

X Stroke	1400	1450	1500	1550	1600	1650	1700	1750	1800	1850	1900	1950	2000	2050	2100	2150	2200
A	3	3	3	3	3	3	3	4	4	4	4	4	4	4	5	5	5
B	188	213	238	263	288	313	138	163	188	213	238	263	288	313	138	163	188
C	18	18	18	18	18	18	22	22	22	22	22	22	22	22	26	26	26

ICSPA3-B2N□HS3M

Load Capacity (kg)

■ B2N□HS3M

		Y-axis Stroke					
		200	300	400	500	600	700
Z-axis Stroke	100	11.5	10.5	9.5	8.4	7.5	6.5
	~200	10.5	9.5	8.5	7.4	6.5	5.5
	~300	9.5	8.5	7.5	6.4	5.5	4.5
	~400	8.4	7.4	6.5	5.4	4.4	3.4

Maximum Speed by Stroke (mm/s)

■ B2N□HS3M

	Stroke							
	100	200	300	400	500	600	700	2250~3000
X-axis	-	-	-	-	-	-	-	2400
Y-axis	1200							-
Z-axis	600			-	-	-	-	-

Dimensions

You can download CAD drawings from our website.

2D CAD

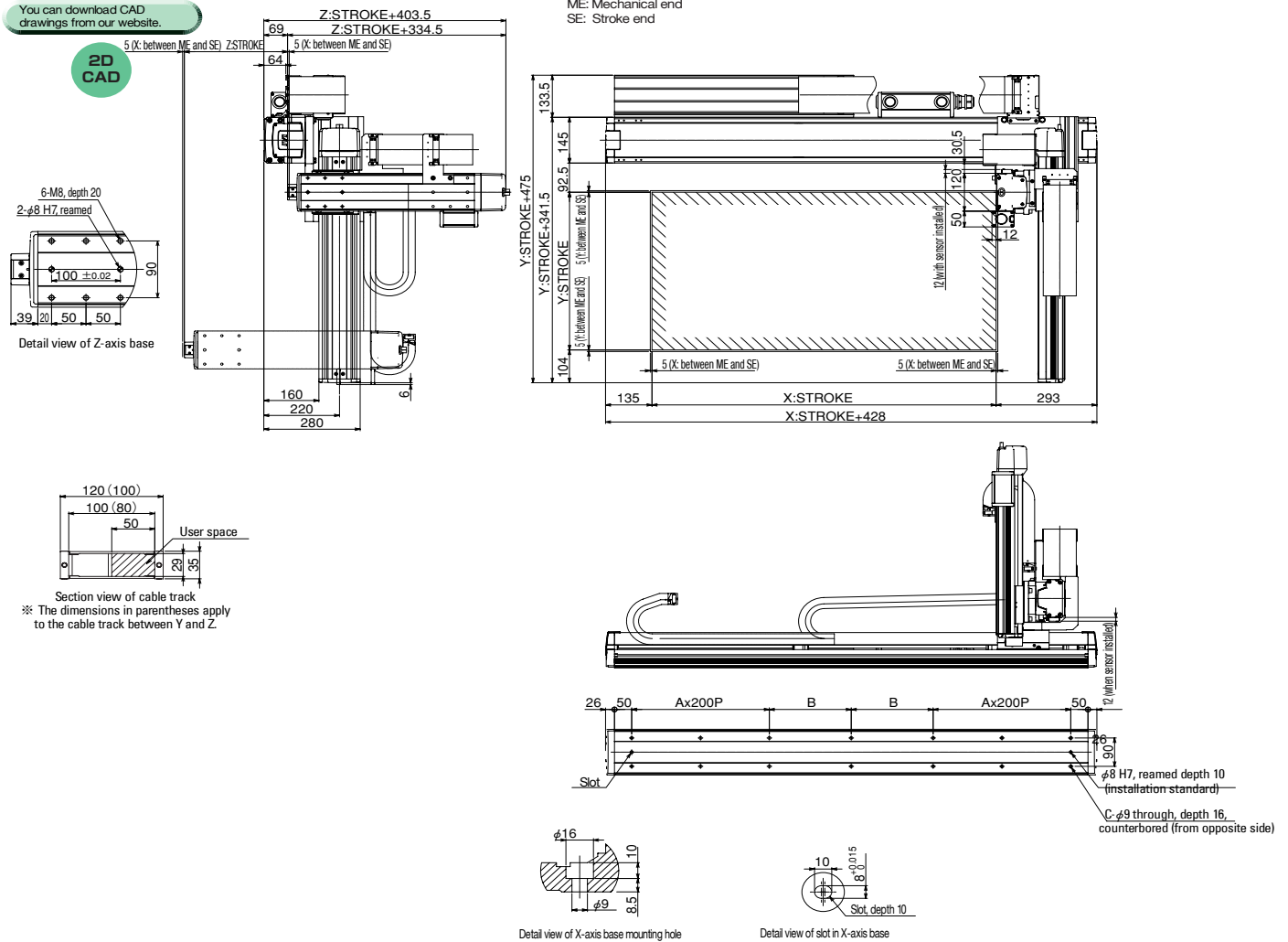

X Stroke	2250	2300	2350	2400	2450	2500	2550	2600	2650	2700	2750	2800	2850	2900	2950	3000
A	5	5	5	6	6	6	6	6	6	6	6	7	7	7	7	7
B	263	288	313	138	163	188	213	238	263	288	313	138	163	188	213	238
C	26	26	26	30	30	30	30	30	30	30	30	34	34	34	34	34

ICSPA3-B2N MS3M

Load Capacity (kg)

B2N MS3M

		Y-axis Stroke					
		200	300	400	500	600	700
Z-axis Stroke	100	13.0					9.1
	~200	11.7					8.1
	~300	10.7					7.1
	~400	9.7					6.1

Maximum Speed by Stroke (mm/s)

B2N MS3M

	Stroke							
	100	200	300	400	500	600	700	2250~3000
X-axis	-	-	-	-	-	-	-	1300
Y-axis	1200							
Z-axis	600		-	-	-	-	-	-

Dimensions

You can download CAD drawings from our website.

2D CAD

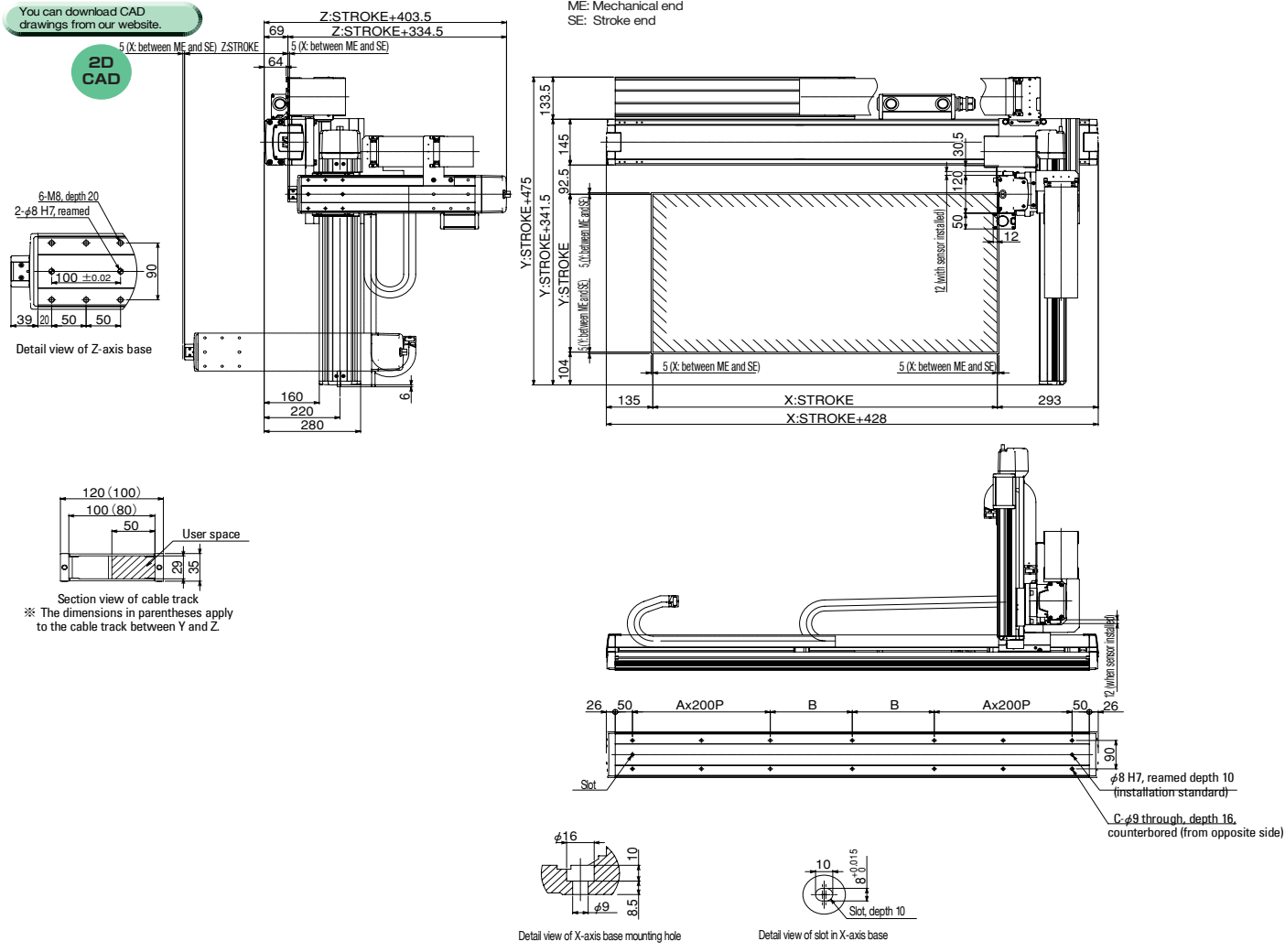

X Stroke	2250	2300	2350	2400	2450	2500	2550	2600	2650	2700	2750	2800	2850	2900	2950	3000
A	5	5	5	6	6	6	6	6	6	6	6	7	7	7	7	7
B	263	288	313	138	163	188	213	238	263	288	313	138	163	188	213	238
C	26	26	26	30	30	30	30	30	30	30	30	34	34	34	34	34

ICSPA4-B3N1H Cartesian robot / Nut rotation type + ISA (4 axes) (2 axes x 2) XYB (Y-axis base mount) / X-axis multi-slider, high-speed type

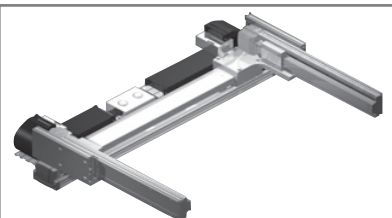

Model Designation ICSPA4 — B3N1H — — — — — — **T2** — —

Series — Type — Encoder Type — X-axis stroke — Options — Y1/Y2 axis stroke — Options — Applicable Controller — Cable Length — Y-axis cable wiring

ICSPA4: High-precision, 4-axis (2 axes + 2 axes) specification
 Refer to the "Model Details" table below.
 A: Absolute specification
 I: Incremental specification (50 mm increments)
 25:250 mm
 225:2250 mm (50 mm increments)
 Options: Refer to the "Options" table
 20:200 mm
 70:700 mm (50 mm increments)
 Refer to the "Options" table
 T2: SCON
 SSEL
 XSEL-P/Q
 3L: 3 m
 5L: 5 m
 L: Specified length
 CT: Cable track

Model Details

Encoder Type	XY combination direction (註 1)	Model
Absolute	1	ICSPA4-B3N1H-A- ①AQRT- ②AG-T2-③ ④
Incremental	1	ICSPA4-B3N1H-I- ①AQRT- ②AG-T2-③ ④

* Refer to the figure below for the XY combination directions.
 * Refer to the table on the right for the details of ① to ④ in the model names shown above.

Explanation of Model Codes

No.	Description	Meaning
①	X-axis stroke (Note 1)	25 : 250mm 225 : 2250mm
②	Y-axis stroke (Note 1)	20 : 200mm 70 : 700mm
③	Cable Length (Note 2)	3L : 3m 5L : 5m □ L : □m
④	Y-axis cable wiring	CT : Cable track

* The above explains the details of ① to ④ in the model names shown to the left. X-axis.

XY Combination Direction

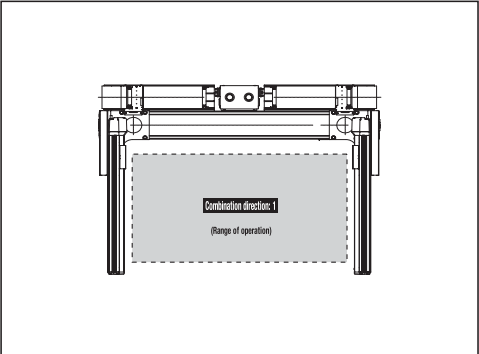

Options

Specify each applicable option code after the stroke of each axis.
 If you are selecting multiple options, specify them in an alphabetical order.

Name	Model	Reference page	Remarks
AQ seal	AQ	P53	Standard feature
Brake	B	P53	Limited to Y-axis
Creep sensor	C	P53	
Home limit switch	L	P53	
Opposite home specification	NM	P53	Limited to Y-axis
Guide with ball retention mechanism	RT	P53	Standard Feature on X-axis

Component Axes

Component Axes	Model
X-axis	NS - LXMM- ①-400-40- (Stroke) -T2-AQ- ② -RT
Y1-axis	ISPA-MYM- ①-200-20- (Stroke) -T2-AQ
Y2-axis	ISPA-MYM- ①-200-10- (Stroke)-T2-AQ

* Enter A (Absolute) or I (Incremental) into ① above.
 * Enter NT1 or NT2 into ② above.
 NT1: Enter for cartesian combination direction 1 or 3
 NT2: Enter for cartesian combination direction 2 or 4
 Note) Nut rotation type and large linear type require a cable track even for single-axis use, but when combined with cartesian robot, they use a different cable track. In this case, the specification will be for no cable track (NT1 or NT2).

Common Specifications

Drive method	Ball screw, rolled, C5 equivalent
Positioning repeatability	±0.01 mm
Lost motion	0.02 mm or less
Guide	Integrated with the base
Base	Material: Aluminum with white alumite treatment
X-axis motor output/lead	400 W/40 mm
Y-axis motor output/lead	200 W/20 mm

Maximum Speed by Stroke (mm/s)

	200	250	300	400	500	600	700	800~2250	
X-axis	—	2400							
Y1-axis, Y2-axis	1200							—	—

Load Capacity by Acceleration (kg) (note 3)

		Y-axis stroke					
		200	300	400	500	600	700
Acceleration	0.3	21.2	20.3	19.4	18.4	17.5	16.6
	0.4	12.2	11.3	10.4	9.4	8.5	7.6
	0.5	7.7	6.8	5.9	4.9	4.0	3.1
	0.6	3.2	2.3	1.4	—	—	—
	0.7	—	—	—	—	—	—
	0.8	—	—	—	—	—	—
	0.9	—	—	—	—	—	—
	1.0	—	—	—	—	—	—

Caution

(Note 1) Strokes are indicated in cm (centimeters) in model names.
 (Note 2) The cable length indicates the length from the X-axis connector box to the controller. Although the standard cable is 3 m or 5 m long, other lengths can be specified in units of meters. The maximum cable length is 20 m.
 (Note 3) The rated acceleration is 0.3 G. Although the actuator can operate at accelerations of up to 1 G, increasing the acceleration decreases the load capacity. (Contact IAI for load capacities at higher accelerations.)

ICSPA4-B3N1H

Dimensions

You can download CAD drawings from our website.

2D CAD

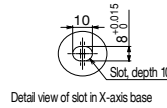
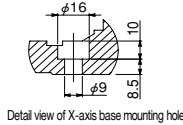
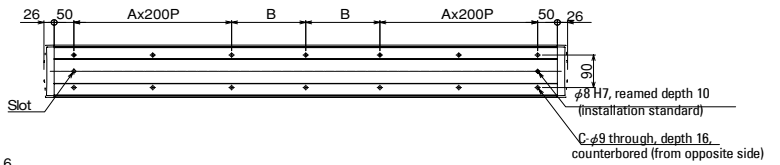
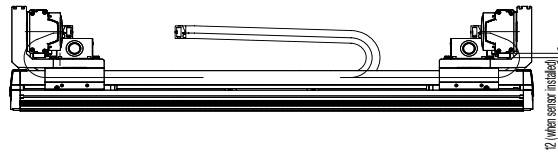
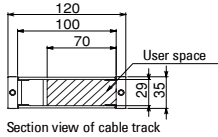
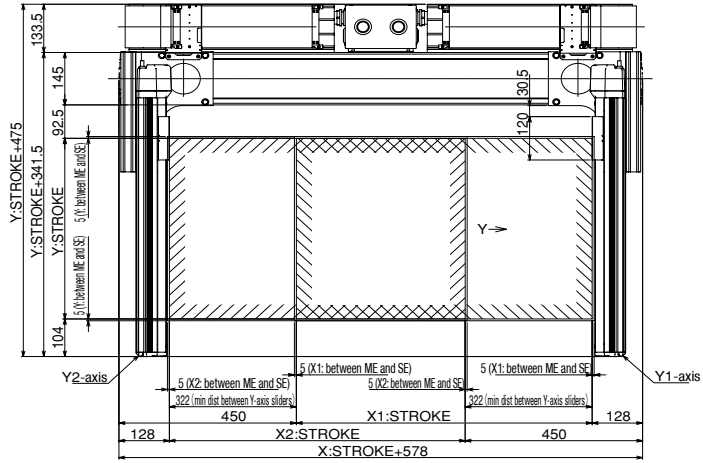
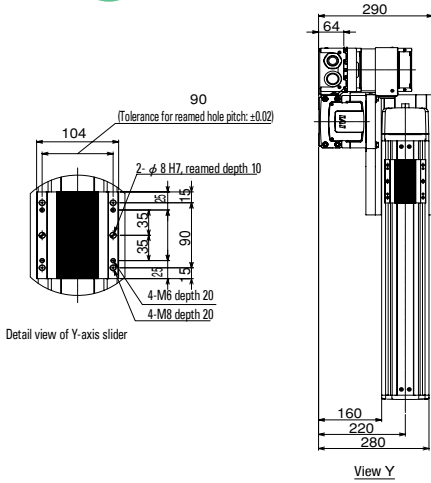

X Stroke	250	300	350	400	450	500	550	600	650	700	750	800	850	900	950	1000	1050	1100	1150	1200
A	1	1	1	1	1	1	1	2	2	2	2	2	2	2	2	2	3	3	3	3
B	138	163	188	213	238	263	288	113	138	163	188	213	238	263	288	313	138	163	188	213
C	10	10	10	10	10	10	10	14	14	14	14	14	14	14	14	14	18	18	18	18

X Stroke	1250	1300	1350	1400	1450	1500	1550	1600	1650	1700	1750	1800	1850	1900	1950	2000	2050	2100	2150	2200	2250
A	3	3	3	3	4	4	4	4	4	4	4	4	5	5	5	5	5	5	5	5	6
B	238	263	288	313	138	163	188	213	238	263	288	313	138	163	188	213	238	263	288	313	138
C	18	18	18	18	22	22	22	22	22	22	22	22	26	26	26	26	26	26	26	26	30

ICSPA4-B3N1M

Cartesian robot / Nut rotation type + ISA (4 axes) (2 axes x 2)
 XYB (Y-axis base mount) X-axis multi-slider, medium-speed type

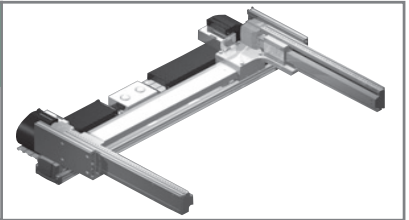

Model Designation **ICSPA4** — **B3N1M** — — — — — — **T2** — —

Series — Type — Encoder Type — X-axis stroke — Options — Y1/Y2 axis stroke — Options — Applicable Controls — Cable Length — Y-axis cable wiring

ICSPA4: High-precision, 4-axis (2 axes + 2 axes) specification
 Refer to the "Model Details" table below.
 A: Absolute specification
 I: Incremental specification (50 mm increments)
 25: 250 mm
 225: 2250 mm (50 mm increments)
 Refer to the "Options" table below
 20: 200 mm
 70: 700 mm (50 mm increments)
 Refer to the "Options" table below
 T2: SCON
 SSEL
 XSEL-P/Q
 3L: 3 m
 5L: 5 m
 L: Specified length
 CT: Cable track (standard)

Model Details

Encoder Type	XY combination direction (*)	Model
Absolute	1	ICSPA4-B3N1M-A- ①AQRT- ②AQ-T2- ③- ④
Incremental	1	ICSPA4-B3N1M-I- ①AQRT- ②AQ-T2- ③- ④

* Refer to the figure below for the XY combination directions.
 * Refer to the table on the right for the details of ① to ④ in the model names shown above.

Explanation of Model Codes

No.	Description	Meaning
①	X-axis stroke (Note 1)	25 : 250mm 225 : 2250mm
②	Y-axis stroke (Note 1)	20 : 200mm 70 : 700mm
③	Cable Length (Note 2)	3L : 3m 5L : 5m □L : □m
④	Y-axis cable wiring	CT : Cable track

* The above explains the details of ① to ④ in the model names shown to the left. X-axis.

XY Combination Direction

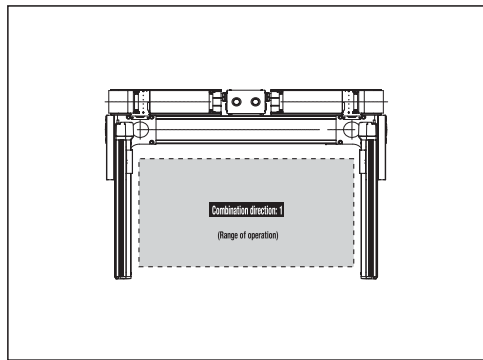

Component Axes

Component Axes	Model
X-axis	NS-LXMM-①-400-20- (Stroke) -T2-AQ-NT1-RT
Y1-axis	ISPA-MYM-①-200-20- (Stroke) -T2-AQ
Y2-axis	ISPA-MYM-①-200-20- (Stroke) -T2-AQ

* Enter A (Absolute) or I (Incremental) into ① above.
 (Note) Nut rotation type and large linear type require a cable track even for single-axis use, but when combined with cartesian robot, they use a different cable track. In this case, the specification will be for no cable track (NT1 or NT2).

Options

Specify each applicable option code after the stroke of each axis.
 If you are selecting multiple options, specify them in an alphabetical order.

Name	Model	Reference page	Remarks
AQ seal	AQ	P53	Standard feature
Brake	B	P53	Limited to Y-axis
Creep sensor	C	P53	
Home limit switch	L	P53	
Opposite home specification	NM	P53	Limited to Y-axis
Guide with ball retention mechanism	RT	P53	Standard Feature on X-axis

Common Specifications

Drive method	Ball screw, rolled, C5 equivalent
Positioning repeatability	±0.01 mm
Lost motion	0.02 mm or less
Guide	Integrated with the base
Base	Material: Aluminum with white alumite treatment
X-axis motor output/lead	400 W/20 mm
Y-axis motor output/lead	200 W/20 mm

Maximum Speed by Stroke (mm/s)

	200	250	300	400	500	600	700	800~2250	
X-axis	—	1300							
Y1-axis, Y2-axis	1200							—	—

Load Capacity by Acceleration (kg) (note 3)

		Y-axis stroke					
		200	300	400	500	600	700
Acceleration	0.3	40.0	40.0	33.0	27.3	22.9	19.3
	0.4	30.0	30.0	30.0	27.3	22.9	19.3
	0.5	21.6	21.6	21.6	21.6	21.6	19.3
	0.6	18.0	18.0	18.0	18.0	17.5	16.6
	0.7	15.3	14.9	14.0	13.0	12.1	11.2
	0.8	12.2	11.3	10.4	9.4	8.5	7.6
	0.9	9.5	8.6	7.7	6.7	5.8	4.9
	1.0	6.8	5.9	5.0	—	—	—

Caution

(Note 1) Strokes are indicated in cm (centimeters) in model names.
 (Note 2) The cable length indicates the length from the X-axis connector box to the controller. Although the standard cable is 3 m or 5 m long, other lengths can be specified in units of meters. The maximum cable length is 20 m.
 (Note 3) The rated acceleration is 0.3 G. Although the actuator can operate at accelerations of up to 1 G, increasing the acceleration decreases the load capacity. (Contact IAI for load capacities at higher accelerations.)

ICSPA4-B3N1M

Dimensions

You can download CAD drawings from our website.

2D CAD

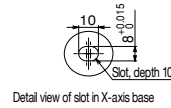
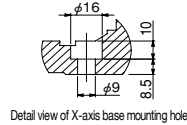
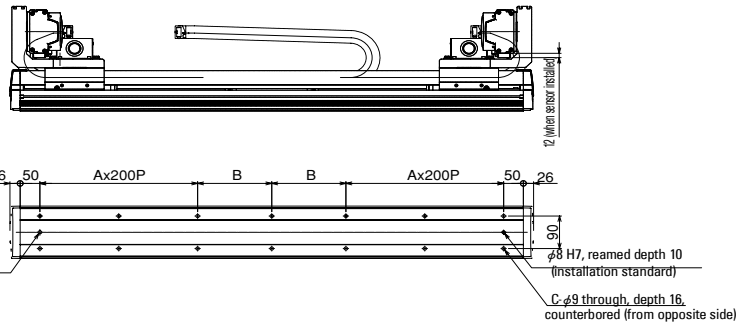
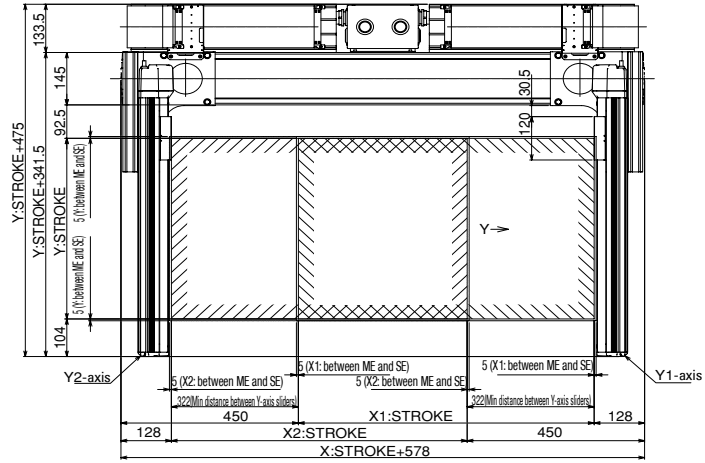
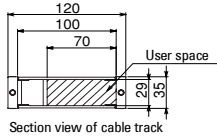
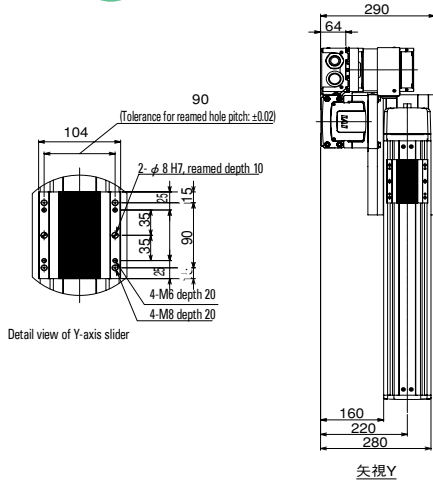

X Stroke	250	300	350	400	450	500	550	600	650	700	750	800	850	900	950	1000	1050	1100	1150	1200
A	1	1	1	1	1	1	1	2	2	2	2	2	2	2	2	2	3	3	3	3
B	138	163	188	213	238	263	288	313	338	363	388	413	438	463	488	513	538	563	588	613
C	10	10	10	10	10	10	10	14	14	14	14	14	14	14	14	14	18	18	18	18

X Stroke	1250	1300	1350	1400	1450	1500	1550	1600	1650	1700	1750	1800	1850	1900	1950	2000	2050	2100	2150	2200	2250
A	3	3	3	3	4	4	4	4	4	4	4	4	5	5	5	5	5	5	5	5	6
B	238	263	288	313	338	363	388	413	438	463	488	513	538	563	588	613	638	663	688	713	738
C	18	18	18	18	22	22	22	22	22	22	22	22	26	26	26	26	26	26	26	26	30

ICSPA6-B3N1MB3

Load Capacity (kg)

B3N1MB3H

		Y-axis Stroke					
		200	300	400	500	600	700
Z-axis Stroke	100	9.0				8.9	
	~200	9.0				7.9	
	~300	9.0				6.9	
	~400	9.0				5.9	
	~500	9.0				4.8	

B3N1MB3M

		Y-axis Stroke					
		200	300	400	500	600	700
Z-axis Stroke	100	19.0			17.0	12.6	8.9
	~200	19.0			16.1	11.6	7.9
	~300	19.0			15.1	10.6	6.9
	~400	19.0			14.1	9.6	5.9
	~500	19.0	18.8	13.0	8.5	4.8	

Maximum Speed by Stroke (mm/s)

B3N1MB3H

	Stroke									
	100	200	250	300	400	500	600	700	800~2250	
X-axis	-	-	1300						-	-
Y-axis	-	1200				-	-	-	-	-
Z-axis	1200			-	-	-	-	-	-	

B3N1MB3M

	Stroke									
	100	200	250	300	400	500	600	700	800~2250	
X-axis	-	-	1300						-	-
Y-axis	-	1200				-	-	-	-	-
Z-axis	600			-	-	-	-	-	-	

Dimensions

You can download CAD drawings from our website.

2D CAD

ME: Mechanical end
SE: Stroke end

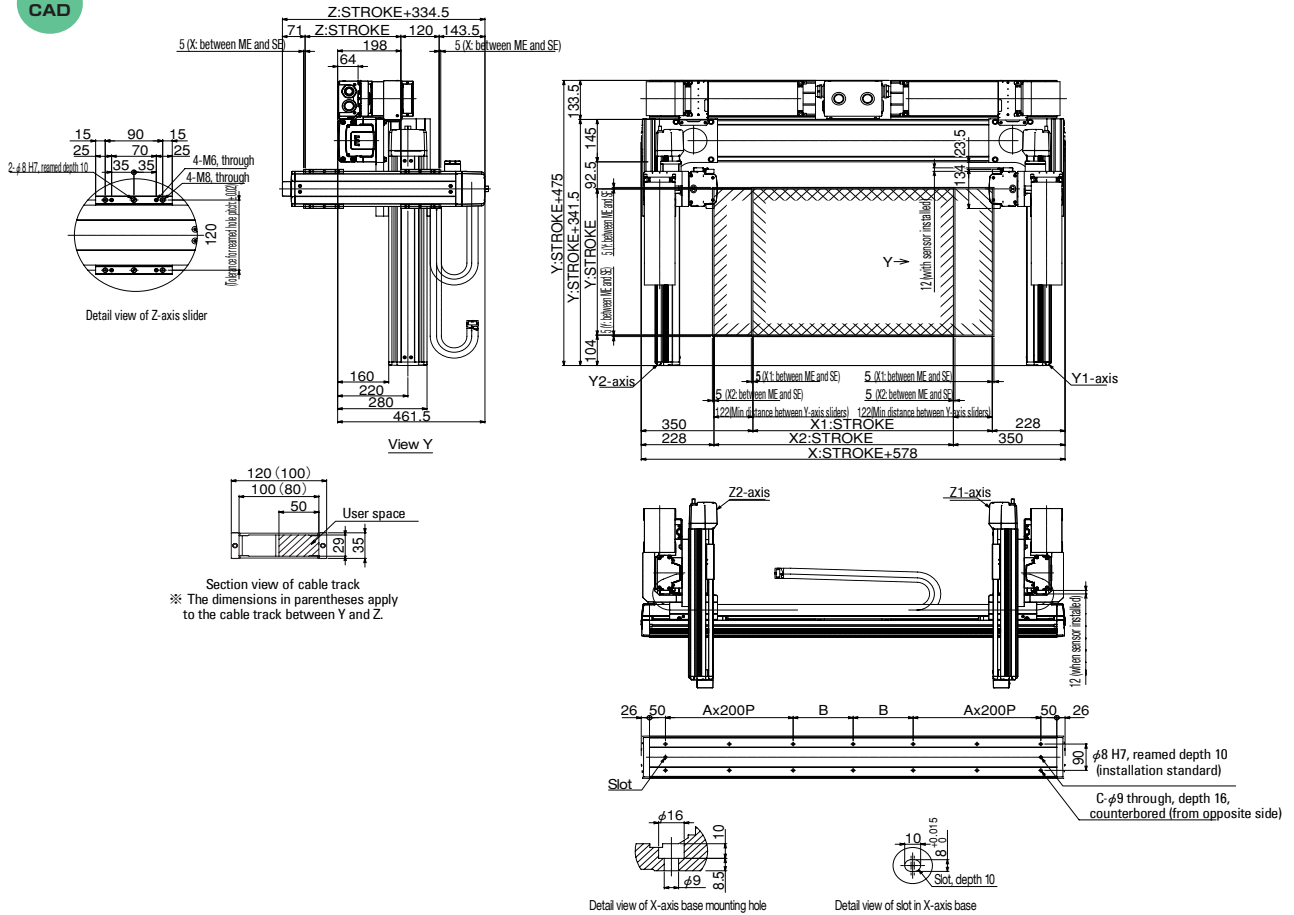

X Stroke	250	300	350	400	450	500	550	600	650	700	750	800	850	900	950	1000	1050	1100	1150	1200
A	1	1	1	1	1	1	1	2	2	2	2	2	2	2	2	2	3	3	3	3
B	138	163	188	213	238	263	288	313	338	363	388	413	438	463	488	513	538	563	588	613
C	10	10	10	10	10	10	10	14	14	14	14	14	14	14	14	14	18	18	18	18

X Stroke	1250	1300	1350	1400	1450	1500	1550	1600	1650	1700	1750	1800	1850	1900	1950	2000	2050	2100	2150	2200	2250
A	3	3	3	3	4	4	4	4	4	4	4	4	5	5	5	5	5	5	5	5	6
B	238	263	288	313	338	363	388	413	438	463	488	513	538	563	588	613	638	663	688	713	738
C	18	18	18	18	22	22	22	22	22	22	22	22	26	26	26	26	26	26	26	26	30

ICSPA6-B3N1HS3M

Cartesian robot / Nut rotation type (6 axes) (3 axes + 3 axes)
X-axis multi-slider, high-speed type Z-axis slider mount

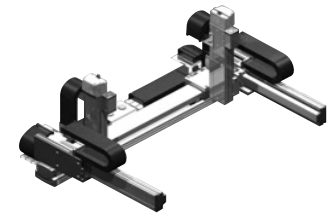

Model Designation **ICSPA6- B3N1HS3M** - [] - [] [] - [] [] - [] [] - **T2** - [] - [] - []

Series - Type - Encoder Type - X-axis stroke Options - Y1-Y2 axis stroke Options - Z-1/Z-2 axis stroke Options - Applicable Controller - Cable Length - Y-axis cable wiring - Z-axis cable wiring

ICSPA6: High-precision, 6-axis (3 axes + 3 axes) specification Refer to the "Model Details" table below.

A: Absolute specification 25:250 mm Refer to the "Options" table below. 20:200 mm Refer to the "Options" table below. 10:100mm Refer to the "Options" table below.

I: Incremental specification 225:2250 mm table below (50 mm increments) 70:700 mm table below (50 mm increments) 40:400mm table below (50 mm increments)

T2: SSEL 3L: 3 m 5L: 5 m XSEL-P/Q []L: Specified length CT: Cable track

Model Details

Encoder Type	XY combination direction (※)	Z-axis speed type	Model
Absolute	1	M	ICSPA6-B3N1HS3M-A-[1]AQRT-[2]AQ-[3]AQBNM-T2-[4]-[5]
Incremental	1	M	ICSPA6-B3N1HS3M-I-[1]AQRT-[2]AQ-[3]AQBNM-T2-[4]-[5]

※ Refer to the figure below for the XY combination directions.
 ※ Refer to the table on the right for the details of [1] to [5] in the model names shown above.

Explanation of Model Codes

No.	Description	Meaning
[1]	X-axis stroke (Note 1)	25 : 250mm 225 : 2250mm
[2]	Y-axis stroke (Note 1)	20 : 200mm 70 : 700mm
[3]	Z-axis stroke (Note 1)	10 : 100mm 40 : 400mm
[4]	Cable Length (Note 2)	3L : 3m 5L : 5m []L : []m
[5]	Y/Z-axis cable wiring	CT : Cable track

※ The above explains the details of [1] to [5] in the model names shown to the left. X-axis.

XY Combination Direction

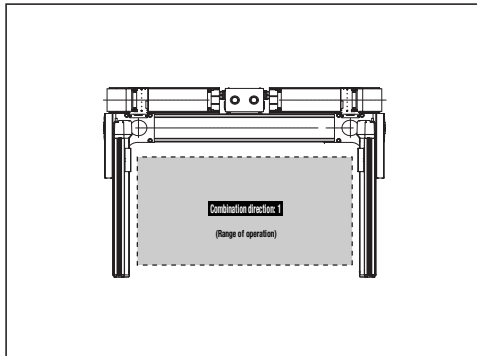

Options

Specify each applicable option code after the stroke of each axis.
 If you are selecting multiple options, specify them in an alphabetical order.

Name	Model	Reference page	Remarks
AQ seal	AQ	→P53	Standard feature
Brake	B	→P53	Limited to Y/Z-axes (Z standard)
Creep sensor	C	→P53	
Home limit switch	L	→P53	
Opposite home specification	NM	→P53	Limited to Y/Z-axes (Z standard)
Guide with ball retention mechanism	RT	→P53	Standard Feature on X-axis

Common Specifications

Drive method	Ball screw, rolled, C5 equivalent
Positioning repeatability	±0.01 mm
Lost motion	0.02 mm or less
Guide	Integrated with the base
Base	Material: Aluminum with white alumite treatment
X-axis motor output/lead	400 W/40 mm
Y-axis motor output/lead	200 W/20 mm
Z-axis motor output/lead	200 W/10 mm

Component Axes

Component Axes	Model
X-axis	NS-LXMM[1]-400-40-(Stroke)-T2-AQ-NT1-RT
Y1-axis	ISPA-MYM[1]-200-20-(Stroke)-T2-AQ
Y2-axis	ISPA-MYM[1]-200-20-(Stroke)-T2-AQ
Z1-axis	ISPA-MZM[1]-200-10-(Stroke)-T2-AQ-B-NM
Z2-axis	ISPA-MZM[1]-200-10-(Stroke)-T2-AQ-B-NM

※ Enter A (Absolute) or I (Incremental) into [1] above.
 ※ The value in parentheses applies to the Z-axis medium-speed specification.
 Note) Nut rotation type and large linear type require a cable track even for single-axis use, but when combined with cartesian robot, they use a different cable track. In this case, the specification will be for no cable track (NT1 or NT2).



Caution

(Note 1) Strokes are indicated in cm (centimeters) in model names.
 (Note 2) The cable length indicates the length from the X-axis connector box to the controller. Although the standard cable is 3 m or 5 m long, other lengths can be specified in units of meters. The maximum cable length is 20 m.
 (Note 3) The rated acceleration is 0.3 G. Although the actuator can operate at accelerations of up to 1 G, increasing the acceleration decreases the load capacity. (Contact IAI for load capacities at higher accelerations.)

ICSPA6-B3N1HS3M

Load Capacity (kg)

B3N1HS3M

		Y-axis Stroke					
		200	300	400	500	600	700
Z-axis Stroke	100	11.5	10.5	9.5	8.4	7.5	6.5
	~200	10.5	9.5	8.5	7.4	6.5	5.5
	~300	9.5	8.5	7.5	6.4	5.5	4.5
	~400	8.4	7.4	6.5	5.4	4.4	3.4

Maximum Speed by Stroke (mm/s)

B3N1HS3M

	Stroke									
	100	200	250	300	400	500	600	700	800~2250	
X-axis	-	-	2400							-
Y-axis	-	1200				-	-	-	-	-
Z-axis	600			-	-	-	-	-	-	

Dimensions

You can download CAD drawings from our website.

2D CAD

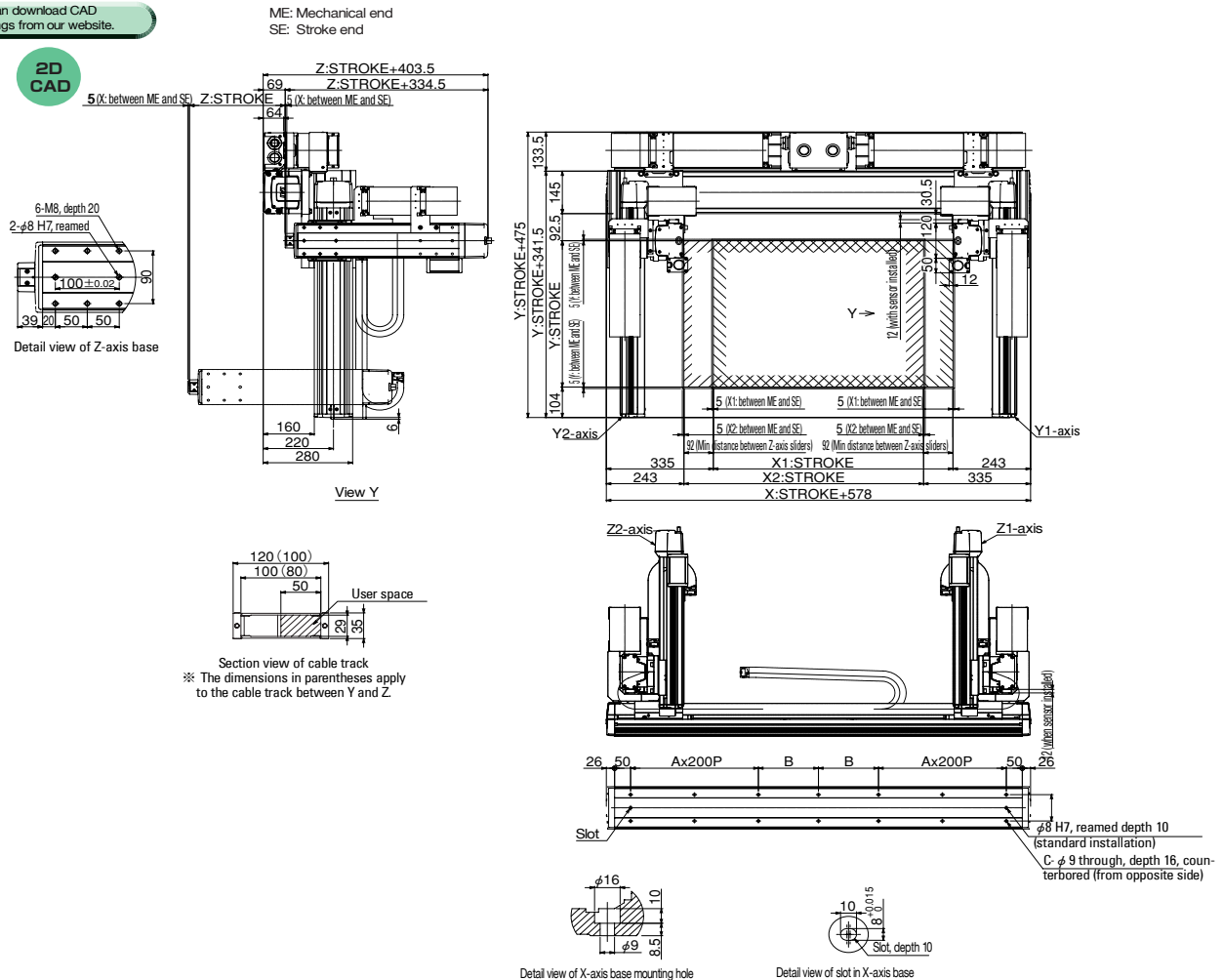

X Stroke	250	300	350	400	450	500	550	600	650	700	750	800	850	900	950	1000	1050	1100	1150	1200
A	1	1	1	1	1	1	1	2	2	2	2	2	2	2	2	2	3	3	3	3
B	138	163	188	213	238	263	288	313	338	363	388	413	438	463	488	513	538	563	588	613
C	10	10	10	10	10	10	10	14	14	14	14	14	14	14	14	14	18	18	18	18

X Stroke	1250	1300	1350	1400	1450	1500	1550	1600	1650	1700	1750	1800	1850	1900	1950	2000	2050	2100	2150	2200	2250
A	3	3	3	3	4	4	4	4	4	4	4	4	5	5	5	5	5	5	5	5	6
B	238	263	288	313	338	363	388	413	438	463	488	513	538	563	588	613	638	663	688	713	738
C	18	18	18	18	22	22	22	22	22	22	22	22	26	26	26	26	26	26	26	26	30

ICSPA6-B3N1MS3M

Cartesian robot / Nut rotation type (6 axes) (3 axes + 3 axes)
X-axis multi-slider, medium-speed type Z-axis slider mount

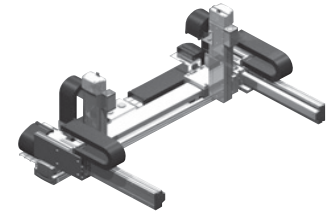

■ Model Designation **ICSPA6- B3N1MS3M** - [] - [] [] - [] [] - [] [] - **T2** - [] - [] - []

Series - Type - Encoder Type - X-axis stroke Options - Y-1/Y-2 axis stroke Options - Z-1/Z-2 axis stroke Options - Appliance Controller - Cable Length - Y-axis scale wiring - Z-axis scale wiring

ICSPA6: High-precision, 6-axis (3 axes + 3 axes) specification Refer to the "Model Details" table below.

A: Absolute 25:250 mm Refer to the specification "Options" 20:200 mm Refer to the "Options" 10:100 mm Refer to the "Options" Refer to the T2:SCON SSEL 3L : 3 m 5L : 5 m CT: Cable track

I: Incremental 225:2250 mm table below specification (50 mm increments) 70:700 mm table below (50 mm increments) 40:400 mm table below (50 mm increments) XSEL-P/Q [] L : Specified length

Model Details

Encoder Type	XY combination direction (*)	Z-axis speed type	Model
Absolute	1	M	ICSPA6-B3N1MS3M-A- ①AQRT- ②AQ- ③AQBNM-T2- ④- ⑤
Incremental	1	M	ICSPA6-B3N1MS3M-I- ①AQRT- ②AQ- ③AQBNM-T2- ④- ⑤

* Refer to the figure below for the XY combination directions.
* Refer to the table on the right for the details of ① to ⑤ in the model names shown above.

Explanation of Model Codes

No.	Description	Meaning
①	X-axis stroke (Note 1)	25 : 250mm 225 : 2250mm
②	Y-axis stroke (Note 1)	20 : 200mm 70 : 700mm
③	Z-axis stroke (Note 1)	10 : 100mm 40 : 400mm
④	Cable Length (Note 2)	3L : 3m 5L : 5m [] L : []m
⑤	Y/Z-axis cable wiring	CT : Cable track

* The above explains the details of ① to ⑤ in the model names shown to the left. X-axis.

XY Combination Direction

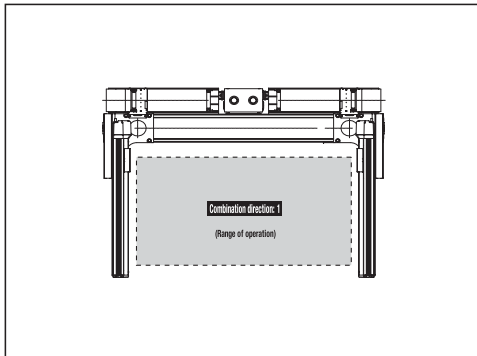

Options

Specify each applicable option code after the stroke of each axis.
If you are selecting multiple options, specify them in an alphabetical order.

Name	Model	Reference page	Remarks
AQ seal	AQ	P53	Standard feature
Brake	B	P53	Limited to Y/Z-axes (Z standard)
Creep sensor	C	P53	
Home limit switch	L	P53	
Opposite home specification	NM	P53	Limited to Y/Z-axes (Z standard)
Guide with ball retention mechanism	RT	P53	Standard Feature on X-axis

Common Specifications

Drive method	Ball screw, rolled, C5 equivalent
Positioning repeatability	±0.01 mm
Lost motion	0.02 mm or less
Guide	Integrated with the base
Base	Material: Aluminum with white alumite treatment
X-axis motor output/lead	400 W/20 mm
Y-axis motor output/lead	200 W/20 mm
Z-axis motor output/lead	200 W/10 mm

Component Axes

Component Axes	Model
X-axis	NS-LXMM-①-400-20-(Stroke) -T2-AQ-NT1-RT
Y1-axis	ISPA-MYM-①-200-20-(Stroke) -T2-AQ
Y2-axis	ISPA-MYM-①-200-20-(Stroke) -T2-AQ
Z1-axis	ISPA-MZM-①-200-10-(Stroke) -T2-AQ-B-NM
Z2-axis	ISPA-MZM-①-200-10-(Stroke) -T2-AQ-B-NM

* Enter A (Absolute) or I (Incremental) into ① above.
* The value in parentheses applies to the Z-axis medium-speed specification.
Note) Nut rotation type and large linear type require a cable track even for single-axis use, but when combined with cartesian robot, they use a different cable track. In this case, the specification will be for no cable track (NT1 or NT2).

Caution

(Note 1) Strokes are indicated in cm (centimeters) in model names.
(Note 2) The cable length indicates the length from the X-axis connector box to the controller. Although the standard cable is 3 m or 5 m long, other lengths can be specified in units of meters. The maximum cable length is 20 m.
(Note 3) The rated acceleration is 0.3 G. Although the actuator can operate at accelerations of up to 1 G, increasing the acceleration decreases the load capacity. (Contact IAI for load capacities at higher accelerations.)

ICSPA6-B3N1MS3M

Load Capacity (kg)

B3N1MS3M

		Y-axis Stroke					
		200	300	400	500	600	700
Z-axis Stroke	100	13.0					9.1
	~200	11.7					8.1
	~300	10.7					7.1
	~400	9.7					6.1

Maximum Speed by Stroke (mm/s)

B3N1MS3M

	Stroke									
	100	200	250	300	400	500	600	700	800~2250	
X-axis	-	-	1300							-
Y-axis	-	1200							-	-
Z-axis	600			-	-	-	-	-	-	

Dimensions

You can download CAD drawings from our website.

2D CAD

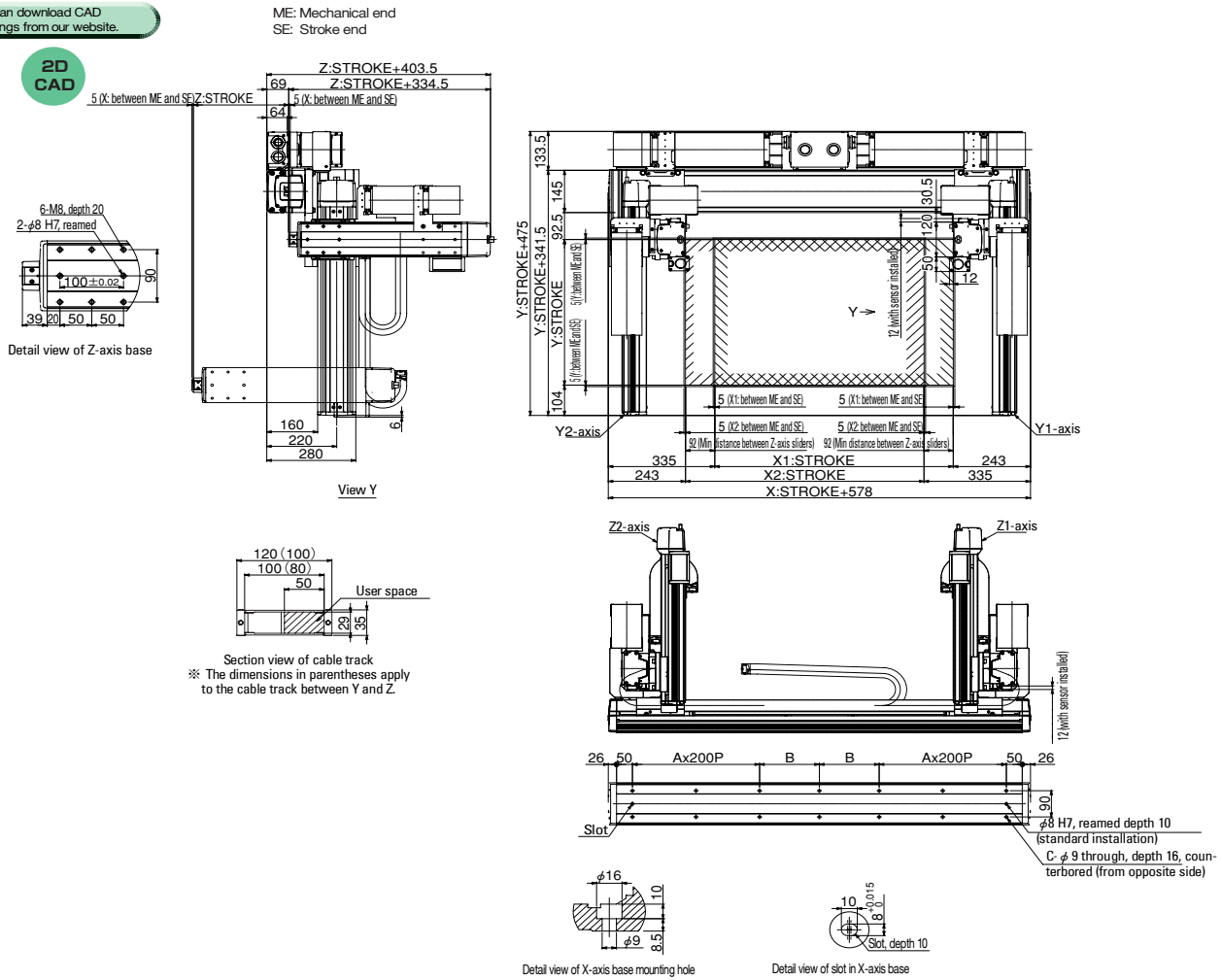

X Stroke	250	300	350	400	450	500	550	600	650	700	750	800	850	900	950	1000	1050	1100	1150	1200
A	1	1	1	1	1	1	1	2	2	2	2	2	2	2	2	2	3	3	3	3
B	138	163	188	213	238	263	288	313	338	363	388	413	438	463	488	513	538	563	588	613
C	10	10	10	10	10	10	10	14	14	14	14	14	14	14	14	14	18	18	18	18

X Stroke	1250	1300	1350	1400	1450	1500	1550	1600	1650	1700	1750	1800	1850	1900	1950	2000	2050	2100	2150	2200	2250
A	3	3	3	3	4	4	4	4	4	4	4	4	5	5	5	5	5	5	5	5	6
B	238	263	288	313	338	363	388	413	438	463	488	513	538	563	588	613	638	663	688	713	738
C	18	18	18	18	22	22	22	22	22	22	22	22	26	26	26	26	26	26	26	26	30

ICSPA2-B1L□H

Cartesian robot / Large linear + ISA (2 axes)
XYB (Y-axis base mount) / X-axis single-slider type

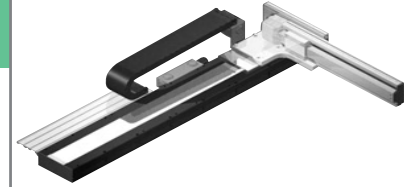

Model Designation ICSPA2 — B1L□H — □ — □ — □ — □ — □ — □ — T2 — □ — □

Series — Type — Encoder Type — X-axis stroke — Options — Y-axis stroke — Options — Applicable Controller — Cable Length — Y-axis cable wiring

ICSPA2: High-precision, 2-axis specification
 B1L□H: Refer to the "Model Details" table below.
 □: Incremental specification
 105:1050 mm
 415:4155 mm (135 mm increments)
 □: Refer to the "Options" table
 20:200 mm
 40:400 mm below (50 mm increments)
 □: Refer to the "Options" table
 T2:SCON
 SSEL
 XSEL-P/Q
 3L: 3 m
 5L: 5 m
 □L: Specified length
 CT: Cable track

Model Details

Encoder Type	XY combination direction (※)	Model
Incremental	1	ICSPA2-B1L1H-I-①L-②AQ-T2-③-④
	2	ICSPA2-B1L2H-I-①L-②AQ-T2-③-④
	3	ICSPA2-B1L3H-I-①L-②AQ-T2-③-④
	4	ICSPA2-B1L4H-I-①L-②AQ-T2-③-④

※ Refer to the figure below for the XY combination directions.
 ※ Refer to the table on the right for the details of ① to ④ in the model names shown above.

Explanation of Model Codes

No.	Description	Meaning
①	X-axis stroke (Note 1)	105 : 1050mm 415 : 4155mm
②	Y-axis stroke (Note 1)	20 : 200mm 40 : 400mm
③	Cable Length (Note 2)	3L : 3m 5L : 5m □L : □m
④	Y-axis cable wiring	CT : Cable track

※ The above explains the details of ① to ④ in the model names shown to the left. X-axis.

XY Combination Direction

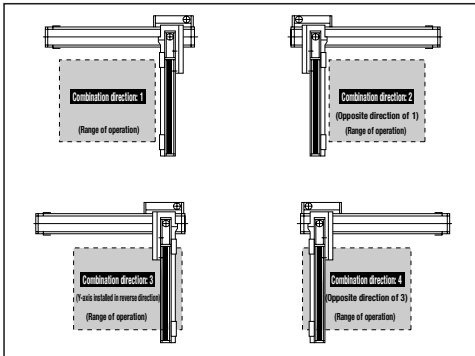

Component Axes

Component Axes	Model
X-axis	LSA-W21SS-I-400 - (Stroke) -T2-L-①
Y-axis	ISPA-MYM-I-200-20-(Stroke)-T2-AQ

※ Enter NT1 or NT2 into ① above.
 NT1: Enter for cartesian combination direction 1 or 3
 NT2: Enter for cartesian combination direction 2 or 4
 (Note) Nut rotation type and large linear type require a cable track even for single-axis use, but when combined with cartesian robot, they use a different cable track. In this case, the specification will be for no cable track (NT1 or NT2).

Load Capacity by Acceleration (kg) (note 3)

		Y-axis stroke				
		200	250	300	350	400
Acceleration	X-axis 1.0 G	21.2	20.0	20.0	17.4	15.2
	Y-axis 0.3 G					

Options

Specify each applicable option code after the stroke of each axis.
 If you are selecting multiple options, specify them in an alphabetical order.

Name	Model	Reference page	Remarks
AQ seal	AQ	→P53	Standard Feature on Y-axis
Brake	B	→P53	Limited to Y-axis
Creep sensor	C	→P53	Limited to Y-axis
Home limit switch	L	→P53	Standard Feature on X-axis
Opposite home specification	NM	→P53	Limited to Y-axis

Common Specifications

Drive method	X-axis: Linear servo motor Y-axis: Ball screw, rolled, C5 equivalent
Positioning repeatability	X-axis: ±0.005 mm Y-axis: ±0.01 mm
Lost motion	0.02 mm or less
Guide	X-axis: Linear guide Y-axis: Guide integrated with the base
Base	X-axis: Material: Aluminum with black alumite treatment Y-axis: Material: Aluminum with white alumite treatment
X-axis motor output/lead	Equivalent to 400 W/(none)
Y-axis motor output/lead	200 W/20 mm

Maximum Speed by Stroke (mm/s)

	200	300	400	1050~4155
X-axis	—	—	—	2500
Y-axis	1200			—

Caution

(Note 1) Strokes are indicated in cm (centimeters) in model names.
 (Note 2) The cable length indicates the length from the X-axis connector box to the controller. Although the standard cable is 3 m or 5 m long, other lengths can be specified in units of meters. The maximum cable length is 20 m.
 (Note 3) The rated acceleration is 1 G for the X-axis and 0.3 G for the Y-axis. Although the Y-axis can operate at accelerations of up to 1 G, increasing the acceleration decreases the load capacity. (Contact IAI for load capacities at higher accelerations.)

ICSPA2-B1L□H

Dimensions

You can download CAD drawings from our website.

2D CAD

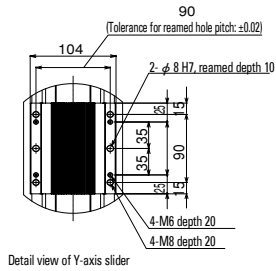

ME: Mechanical end
SE: Stroke end

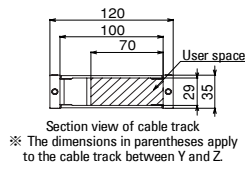
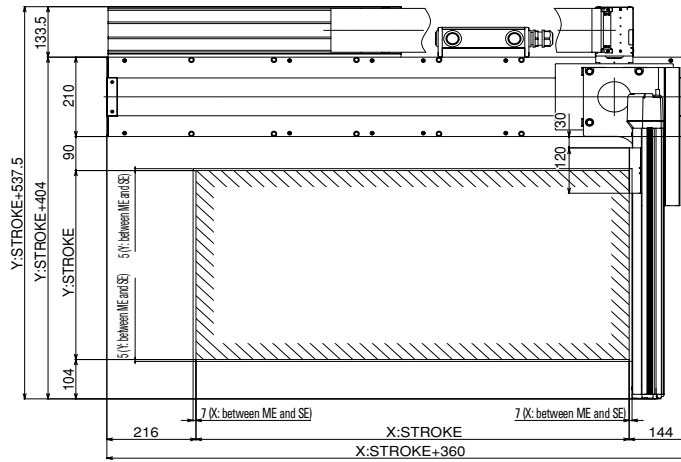
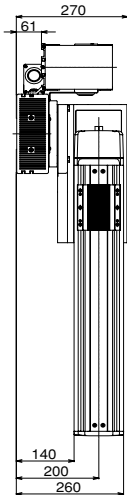

C-φ9 through, depth 16, counter-bored (from opposite side)

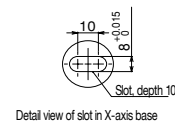
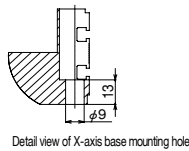
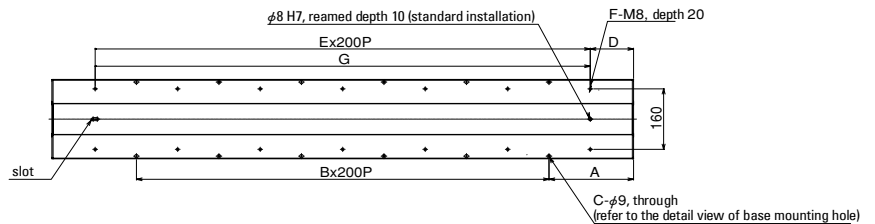
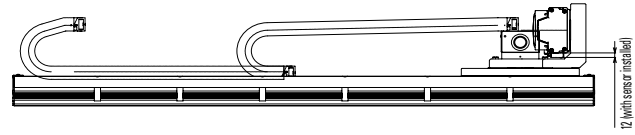

X Stroke	1050	1185	1320	1455	1590	1725	1860	1995	2130	2265	2400	2535
A	205	72.5	140	207.5	75	142.5	210	77.5	145	212.5	80	147.5
B	5	7	7	7	9	9	9	11	11	11	13	13
C	12	16	16	16	20	20	20	24	24	24	28	28
D	105	172.5	40	107.5	175	42.5	110	177.5	45	112.5	180	47.5
E	6	6	8	8	8	10	10	10	12	12	12	14
F	14	14	18	18	18	22	22	22	26	26	26	30
G	1200	1200	1600	1600	1600	2000	2000	2000	2400	2400	2400	2800

X Stroke	2670	2805	2940	3075	3210	3345	3480	3615	3750	3885	4020	4155
A	215	82.5	150	217.5	85	152.5	220	87.5	155	222.5	90	157.5
B	13	15	15	15	17	17	17	19	19	19	21	21
C	28	32	32	32	36	36	36	40	40	40	44	44
D	115	182.5	50	117.5	185	52.5	120	187.5	55	122.5	190	57.5
E	14	14	16	16	16	18	18	18	20	20	20	22
F	30	30	34	34	34	38	38	38	42	42	42	46
G	2800	2800	3200	3200	3200	3600	3600	3600	4000	4000	4000	4400

ICSPA3-B1L□HS3M

Load Capacity (kg)

■ B1L□HS3M

		Y-axis Stroke				
		200	250	300	350	400
Z-axis Stroke	100	11.5	10.2	7.6	5.3	
	~200	10.5	9.2	6.6	4.3	
	~300	9.5	8.2	5.5	3.3	

Maximum Speed by Stroke (mm/s)

■ B1L□HS3M

	Stroke				
	100	200	300	400	1050~4155
X-axis	-	-	-	-	2500
Y-axis	-	1200		-	-
Z-axis	600		-	-	-

Dimensions

You can download CAD drawings from our website.

ME: Mechanical end
SE: Stroke end

2D CAD

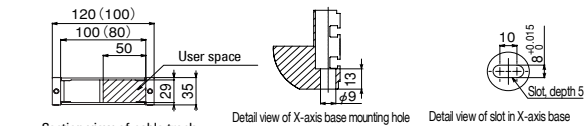
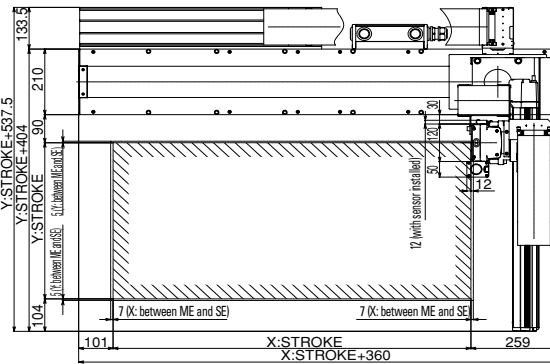
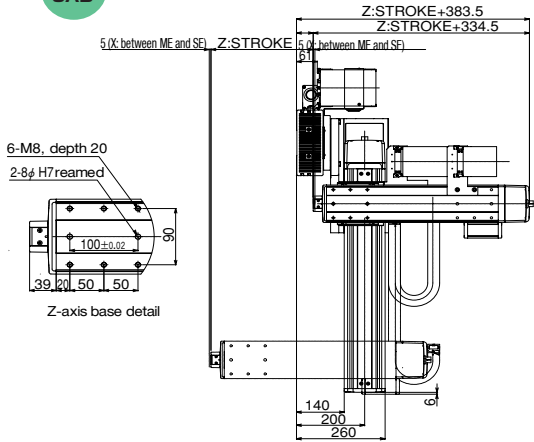

Section view of cable track
※ The dimensions in parentheses apply to the cable track between Y and Z.

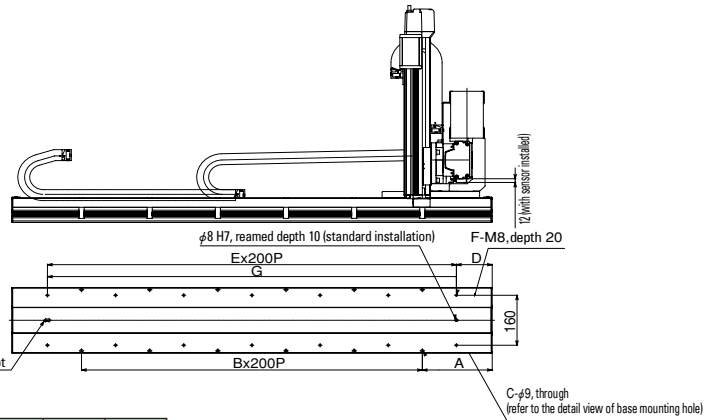

X Stroke	1050	1185	1320	1455	1590	1725	1860	1995	2130	2265	2400	2535
A	205	72.5	140	207.5	75	142.5	210	77.5	145	212.5	80	147.5
B	5	7	7	7	9	9	9	11	11	11	13	13
C	12	16	16	16	20	20	20	24	24	24	28	28
D	105	172.5	40	107.5	175	42.5	110	177.5	45	112.5	180	47.5
E	6	6	8	8	8	10	10	10	12	12	12	14
F	14	14	18	18	18	22	22	22	26	26	26	30
G	1200	1200	1600	1600	1600	2000	2000	2000	2400	2400	2400	2800

X Stroke	2670	2805	2940	3075	3210	3345	3480	3615	3750	3885	4020	4155
A	215	82.5	150	217.5	85	152.5	220	87.5	155	222.5	90	157.5
B	13	15	15	15	17	17	17	19	19	19	21	21
C	28	32	32	32	36	36	36	40	40	40	44	44
D	115	182.5	50	117.5	185	52.5	120	187.5	55	122.5	190	57.5
E	14	14	16	16	16	18	18	18	20	20	20	22
F	30	30	34	34	34	38	38	38	42	42	42	46
G	2800	2800	3200	3200	3200	3600	3600	3600	4000	4000	4000	4400

ICSPA4-B2L1H

Cartesian robot / Large linear + ISA (4 axes) (2 axes x 2)
XYB (Y-axis base mount) / X-axis multi-slider type

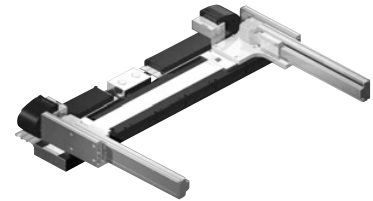

Model Designation **ICSPA4** — **B2L1H** — — — — — — **T2** — —

Series — Type — Encoder Type — X-axis stroke — Options — Y-axis stroke — Options — Applicable Controller — Cable Length — Y-axis cable wiring

ICSPA4: High-precision, 4-axis (2 axes + 2 axes) specification
B2L1H: Refer to the "Model Details" table below.
Incremental specification: 73:730 mm, 383:3835 mm (135 mm increments)
Options: Refer to the "Options" table below
Y-axis stroke: 20:200 mm, 40:400 mm (50 mm increments)
Options: Refer to the "Options" table below
Applicable Controller: T2:SCON, SSEL, XSEL-P/Q
Cable Length: 3L: 3 m, 5L: 5 m
Y-axis cable wiring: CT: Cable track
□L: Specified length

Model Details

Encoder Type	XY combination direction (※)	Model
Incremental	1	ICSPA4-B2L1H-I-①L-②AQ-T2-③-④

※ Refer to the figure below for the XY combination directions.
※ Refer to the table on the right for the details of ① to ④ in the model names shown above.

Explanation of Model Codes

No.	Description	Meaning
①	X-axis stroke (Note 1)	73 : 730mm 383 : 3835mm
②	Y-axis stroke (Note 1)	20 : 200mm 40 : 400mm
③	Cable Length (Note 2)	3L : 3m 5L : 5m □L : □m
④	Y-axis cable wiring	CT : Cable track

※ The above explains the details of ① to ④ in the model names shown to the left. X-axis.

XY Combination Direction

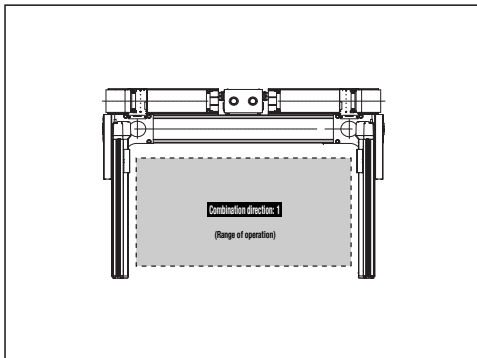

Options

Specify each applicable option code after the stroke of each axis.
If you are selecting multiple options, specify them in an alphabetical order.

Name	Model	Reference page	Remarks
AQ seal	AQ	→P53	Standard Feature on Y-axis
Brake	B	→P53	Limited to Y-axis
Creep sensor	C	→P53	Limited to Y-axis
Home limit switch	L	→P53	Standard Feature on X-axis
Opposite home specification	NM	→P53	Limited to Y-axis

Common Specifications

Drive method	X-axis: Linear servo motor Y-axis: Ball screw, rolled, C5 equivalent
Positioning repeatability	X-axis: ±0.005 mm Y-axis: ±0.01 mm
Lost motion	0.02 mm or less
Guide	X-axis: Linear guide Y-axis: Guide integrated with the base
Base	X-axis: Material: Aluminum with black alumite treatment Y-axis: Material: Aluminum with white alumite treatment
X-axis motor output/lead	Equivalent to 400 W/(none)
Y-axis motor output/lead	200 W/20 mm

Maximum Speed by Stroke (mm/s)

	200	300	400	730~3835
X-axis	—	—	—	2500
Y-axis	1200			—

Component Axes

Component Axes	Model
X-axis	LSA-W21SM-I-400 - (Stroke) -T2-L-NT-1
Y1-axis	ISPA-MYM-I-200-20-(Stroke)-T2-AQ
Y2-axis	ISPA-MYM-I-200-20-(Stroke)-T2-AQ

Note) Nut rotation type and large linear type require a cable track even for single-axis use, but when combined with cartesian robot, they use a different cable track. In this case, the specification will be for no cable track (NT1 or NT2).

Load Capacity by Acceleration (kg) (note 3)

		Y-axis stroke				
		200	250	300	350	400
Acceleration	X-axis 1.0 G	21.2	20.0	20.0	17.4	15.2
	Y-axis 0.3 G					



Caution

(Note 1) Strokes are indicated in cm (centimeters) in model names.
(Note 2) The cable length indicates the length from the X-axis connector box to the controller. Although the standard cable is 3 m or 5 m long, other lengths can be specified in units of meters. The maximum cable length is 20 m.
(Note 3) The rated acceleration is 1 G for the X-axis and 0.3 G for the Y-axis. Although the Y-axis can operate at accelerations of up to 1 G, increasing the acceleration decreases the load capacity. (Contact IAI for load capacities at higher accelerations.)

ICSPA4-B2L H

Dimensions

You can download CAD drawings from our website.

2D CAD

ME: Mechanical end
SE: Stroke end

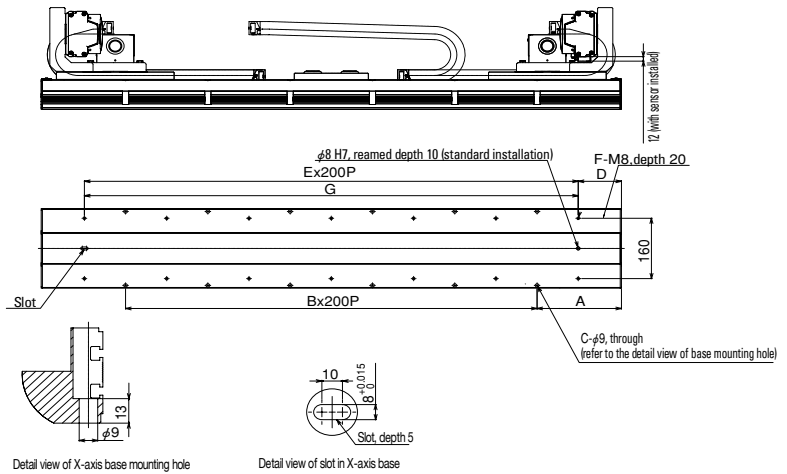
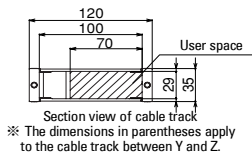
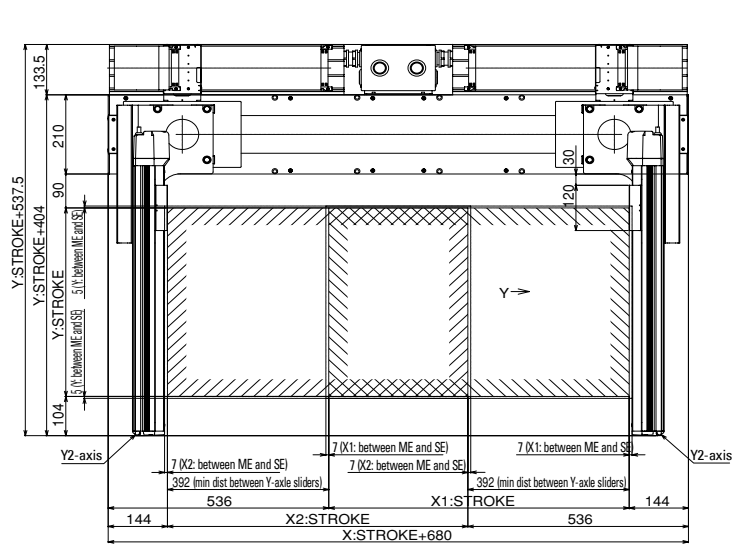
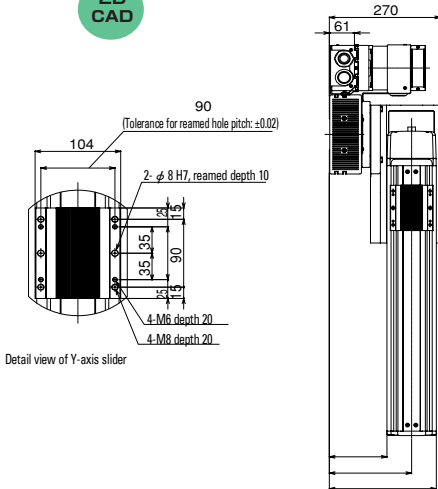

X Stroke	730	865	1000	1135	1270	1405	1540	1675	1810	1945	2080	2215
A	205	72.5	140	207.5	75	142.5	210	77.5	145	212.5	80	147.5
B	5	7	7	7	9	9	9	11	11	11	13	13
C	12	16	16	16	20	20	20	24	24	24	28	28
D	105	172.5	40	107.5	175	42.5	110	177.5	45	112.5	180	47.5
E	6	6	8	8	8	10	10	10	12	12	12	14
F	14	14	18	18	18	22	22	22	26	26	26	30
G	1200	1200	1600	1600	1600	2000	2000	2000	2400	2400	2400	2800

X Stroke	2350	2485	2620	2755	2890	3025	3160	3295	3430	3565	3700	3835
A	215	82.5	150	217.5	85	152.5	220	87.5	155	222.5	90	157.5
B	13	15	15	15	17	17	17	19	19	19	21	21
C	28	32	32	32	36	36	36	40	40	40	44	44
D	115	182.5	50	117.5	185	52.5	120	187.5	55	122.5	190	57.5
E	14	14	16	16	16	18	18	18	20	20	20	22
F	30	30	34	34	34	38	38	38	42	42	42	46
G	2800	2800	3200	3200	3200	3600	3600	3600	4000	4000	4000	4400

ICSPA6-B2L1HS3M

Load Capacity (kg)

B2L1HS3M

		Y-axis Stroke				
		200	250	300	350	400
Z-axis Stroke	100	11.5	10.2	7.6	5.3	
	~200	10.5	9.2	6.6	4.3	
	~300	9.5	8.2	5.5	3.3	

Maximum Speed by Stroke (mm/s)

B2L1HS3M

	Stroke				
	100	200	300	400	730~3835
X-axis	-	-	-	-	2500
Y-axis	-	1200			
Z-axis	600		-	-	-

Dimensions

You can download CAD drawings from our website.

2D CAD

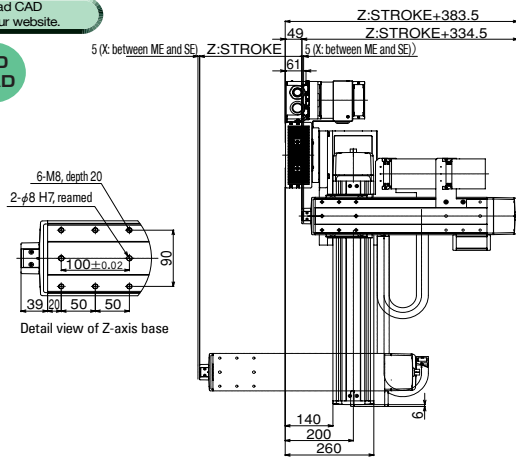

ME: Mechanical end
SE: Stroke end

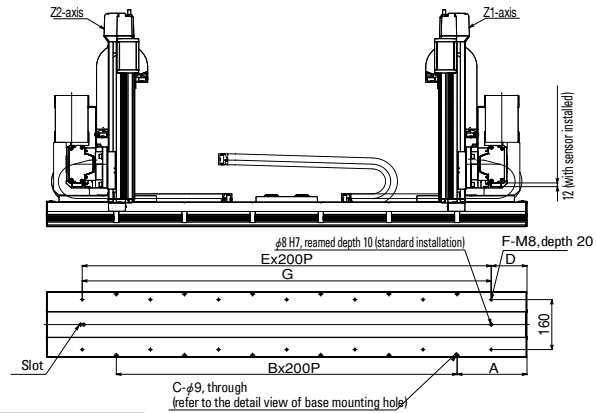
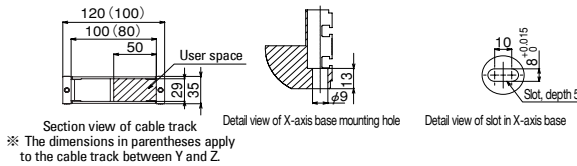
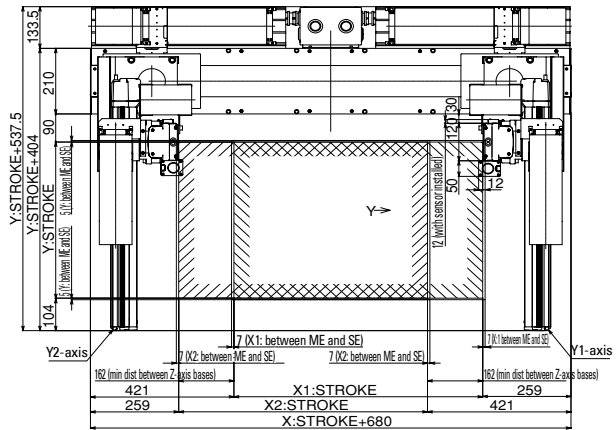

X Stroke	730	865	1000	1135	1270	1405	1675	540	1810	1945	2080	2215
A	205	72.5	140	207.5	75	142.5	210	77.5	145	212.5	80	147.5
B	5	7	7	7	9	9	9	11	11	11	13	13
C	12	16	16	16	20	20	20	24	24	24	28	28
D	105	172.5	40	107.5	175	42.5	110	177.5	45	112.5	180	47.5
E	6	6	8	8	8	10	10	10	12	12	12	14
F	14	14	18	18	18	22	22	22	26	26	26	30
G	1200	1200	1600	1600	1600	2000	2000	2000	2400	2400	2400	2800

X Stroke	2350	2485	2620	2755	2890	3025	3160	3295	3430	3565	3700	3835
A	215	82.5	150	217.5	85	152.5	220	87.5	155	222.5	90	157.5
B	13	15	15	15	17	17	17	19	19	19	21	21
C	28	32	32	32	36	36	36	40	40	40	44	44
D	115	182.5	50	117.5	185	52.5	120	187.5	55	122.5	190	57.5
E	14	14	16	16	16	18	18	18	20	20	20	22
F	30	30	34	34	34	38	38	38	42	42	42	46
G	2800	2800	3200	3200	3200	3600	3600	3600	4000	4000	4000	4400

Explanation of Actuator Options

■ **AQ Seal [Standard Feature]** ※This option cannot be installed on large linear servo actuators.

Model **AQ**

Explanation The AQ seal is a lubrication unit that uses a lubricating member made by resin-hardened lubricating oil. As the AQ seal contacts the guide and ball screw, lubricating oil is supplied. This, combined with regular greasing, will keep the actuator maintenance-free for a long period.

■ **Brake [Standard feature on Z-axes]** ※This option cannot be installed on large linear servo actuators.

Model **B**

Explanation The brake is a holding mechanism that prevents the Z-axis slider or Z-axis itself from dropping to cause damage to the load when the power or servo is turned off. The Z-axis of each Cartesian robot comes standard with the brake.

■ **Creep Sensor**

Model **C**

Explanation This sensor is used on actuators of incremental specifications to shorten the time of home return operation by allowing the slider to move at high speed during home return until just before the home, and then reduce the speed to the normal home return speed once the sensor is passed. The creep sensor is installed inside the actuator housing on NS actuators. It is installed on the side face of the housing on ISA actuators.

■ **Home Limit Switch [Standard feature on large linear actuators]**

Model **L**

Explanation NS and ISA actuators adopt the "push-motion method" for their home return operation, whereby the home is established upon sensing of phase Z after the slider has contacted the stopper and reversed.

This optional home limit switch is used to reverse the slider during home return based on a proximity sensor signal, instead of slider contact with the stopper. Large linear actuators come standard with the home limit switch.

■ **Opposite Home Specification**

Model **NM**

Explanation On the standard specification, the home is set on the motor side (on the NS and LSA, the motor side means the side corresponding to the reamed holes in the base). However, you can specify the home to be set on the opposite side. (To change the home direction, the encoder must be adjusted. Accordingly, be sure to specify the opposite home option when placing your order. Note that multi-slider types do not support the opposite home specification.)

■ **Guide with Ball Retention Mechanism [Standard feature]** ※This option cannot be installed on large linear servo actuators.

Model **RT**

Explanation This ball retention mechanism achieves a long period of maintenance-free operation and longer life, thanks to the spacers inserted between the balls (steel balls) in the guide to suppress collision between the balls.

NS actuators come standard with the guide with ball retention mechanism.

■ **List of Options by Axis**

○ : Installable × : Not installable

	NS Actuator	ISA Actuator	LSA Actuator
AQ seal	Standard feature	Standard feature	×
Brake	× (※1)	○	×
Creep sensor	○	○	×
Home limit switch	○	○	Standard feature
Opposite home specification	× (※2)	○	× (※2)
Guide with ball retention mechanism	Standard feature	○	×

(※1) Brake settings are available for vertical specification, but not for horizontal specification.

(※2) When using the X-axis in opposite home specification, follow instructions for the XY combined direction.

SSEL



Program controller for one or two axes

Model List/Prices

A program controller capable of operating RCS2-series actuators. Various controls can be performed with a single controller.

Type	C	
Name	Program mode	Positioner mode
Exterior View		
Description	The controller can communicate with the actuator and external devices without requiring any additional device. When two axes are operated, this controller lets you perform arc interpolation, path operation and synchronized operation.	Up to 20,000 positioning points are supported. Push-motion operation and teaching operation are also possible.
Number of Positions	20,000 points	

Explanation

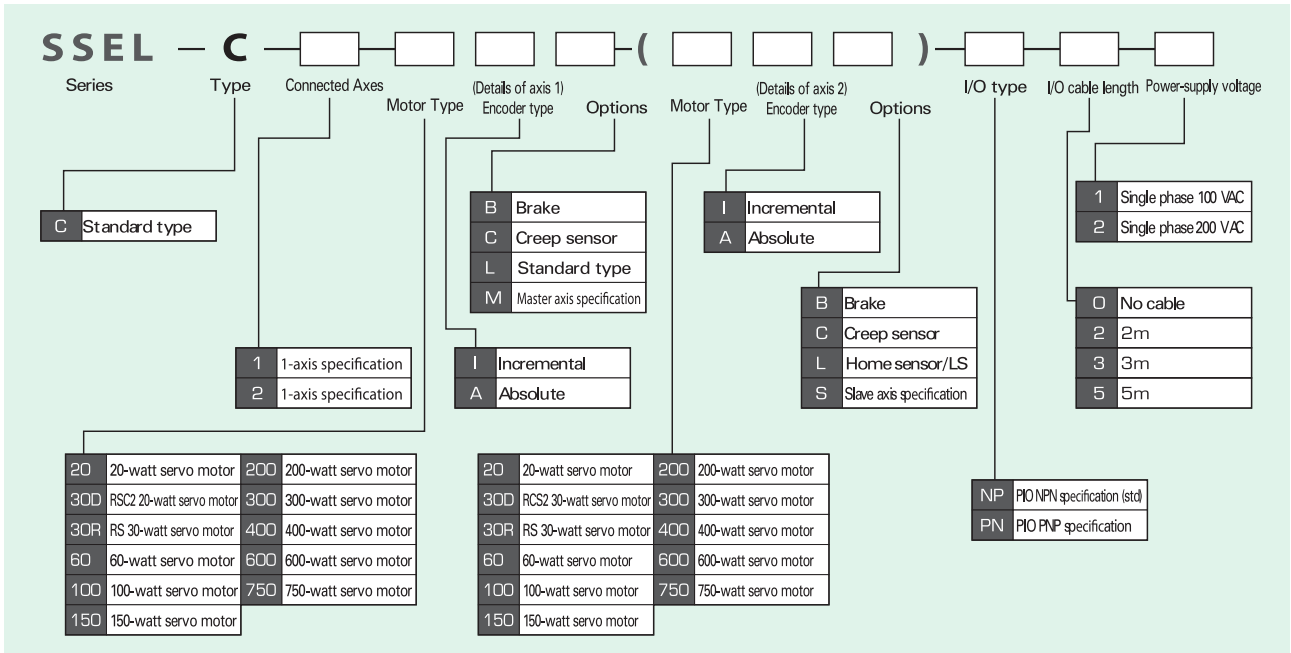

System Configuration

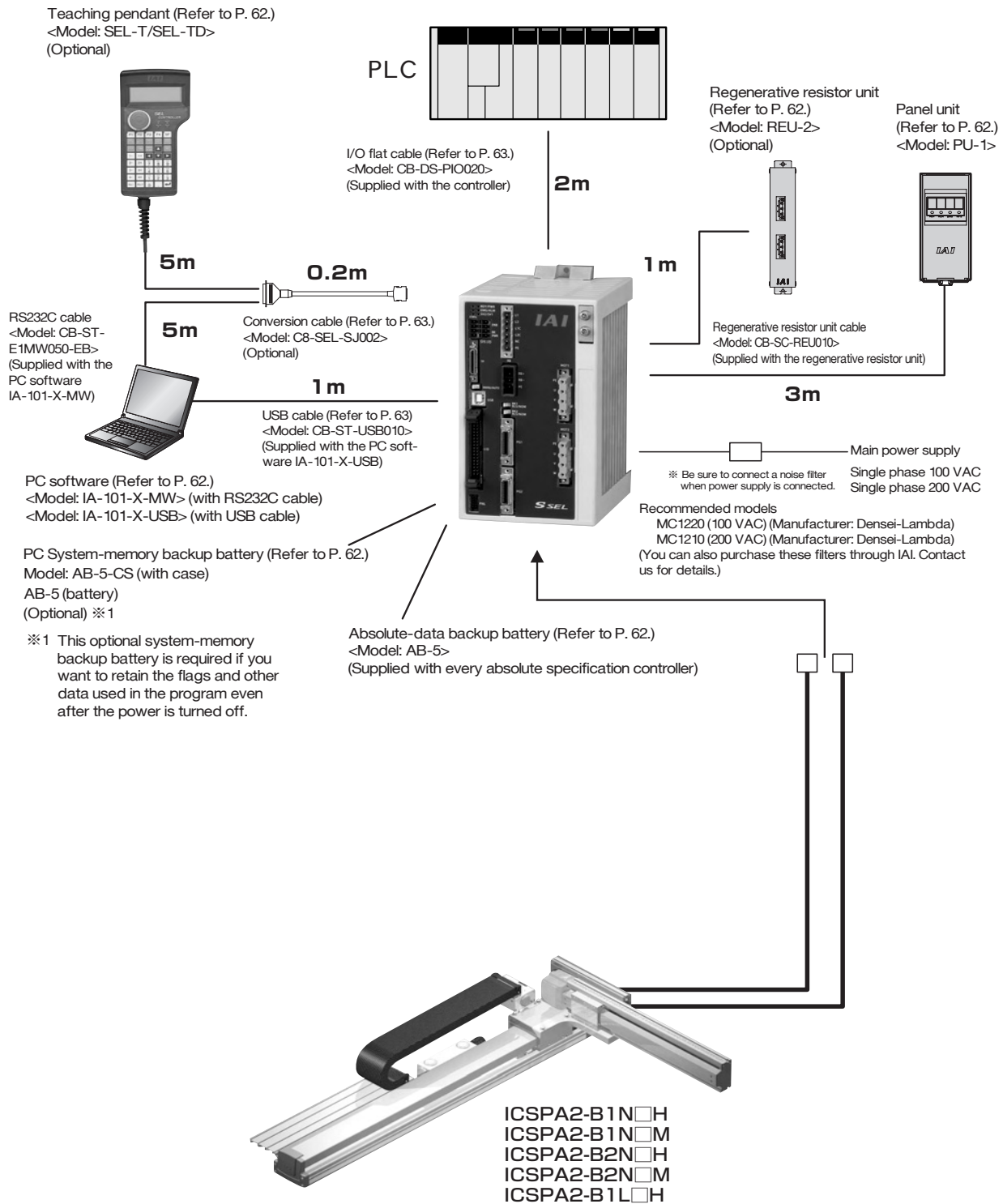

I/O Specifications

Input External Input Specifications

Item	Specification
Input voltage	DC 24 V ± V 10%
Input current	7 mA per circuit
ON/OFF voltages	ON voltage (min.) OFF voltage (max.)t
Insulation method	Photo coupler

NPN specification

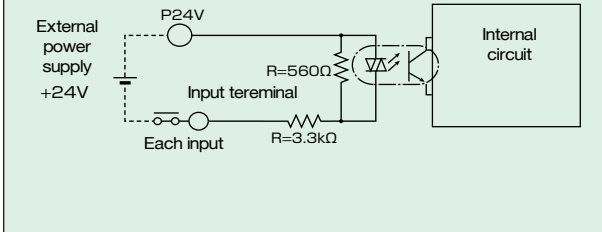

PNP specification

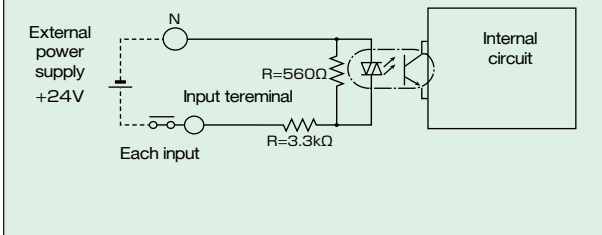

Output External Output Specifications

Item	Item
Load voltage	DC 24 V
Maximum load current	100 mA per point, total 400 mA for 8 points
Leak current (max.)	Max. 0.1 mA per point
Insulation method	Photo-coupler

NPN specification

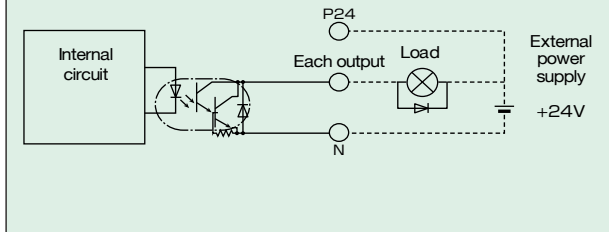

PNP specification

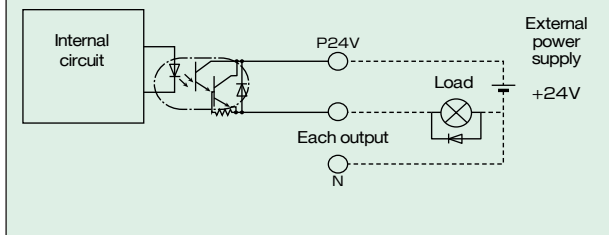

Explanation of I/O Functions

The SSEL controller can be operated in the "program mode" where the actuator is operated by a program input to the controller, or "positioner mode" where the actuator is moved to the positions specified by signals received from a host PLC. The positioner mode includes the five input patterns shown below to support various applications.

Functions by Controller Type

Operation mode	Features	
Program mode	Super SEL, a language that enables programming of complex controls using simple commands, lets you perform linear/smooth interpolation operation, path movement operation ideal for coating application, etc., arch motion/palletizing operation, and many other operations with ease.	
Positioner mode	Standard mode	The basic operation mode, where all you need is to specify position number and input a start signal. Push-motion operation and 2-axis linear interpolation operation are also supported.
	Type-switching mode	In certain applications such as when multiple loads of the same shape but slightly different hole positions are handled, you can issue movement commands to the same position number by changing only the type number.
	2-axis independent mode	With a 2-axis controller, the two axes can be operated independently using separate commands.
	Teaching mode	The slider (rod) can be moved with an external signal to register the stopped position as position data.
	DS-S-C1 compatible mode	If you have been using a DS-S-C1 controller, you can replace it with an SSEL controller without having to change the host programs. * Compatibility with actuators is not assured.

Explanation of I/O Functions

Program Mode

PIN No.	Category	Port No.	Program mode	Function	
1A	P24		24-V input	Connect 24-V.	
1B	Input	016	Program No.1 selection	Select the program number corresponding to the program you want to start. (Specify a desired port from 016 to 022 using a BCD code.)	
2A		017	Program No.2 selection		
2B		018	Program No.4 selection		
3A		019	Program No.8 selection		
3B		020	Program No.10 selection		
4A		021	Program No.20 selection		
4B		022	Program No.40 selection		
5A		023	CPU reset		The system is reset and enters the same state achieved when the power has been turned off and then turned back on.
5B		000	Start		The program corresponding to the selected port between Nos. 016 and 022 is started.
6A		001	General-purpose input		The controller waits for an external input following each program command.
6B		002	General-purpose input		
7A		003	General-purpose input		
7B		004	General-purpose input		
8A		005	General-purpose input		
8B		006	General-purpose input		
9A		007	General-purpose input		
9B	008	General-purpose input			
10A	009	General-purpose input			
10B	010	General-purpose input			
11A	011	General-purpose input			
11B	012	General-purpose input			
12A	013	General-purpose input			
12B	014	General-purpose input			
13A	015	General-purpose input			
13B	Output	300	Alarm	This signal is output when an alarm has occurred. (Contact B)	
14A		301	Ready	This signal is output when the controller has started properly and become ready.	
14B		302	General-purpose input	These signals can be turned ON/OFF freely using program commands.	
15A		303	General-purpose input		
15B		304	General-purpose input		
16A		305	General-purpose input		
16B		306	General-purpose input		
17A	307	General-purpose input			
17B	N		OV input	Connect OV.	

Wiring diagram

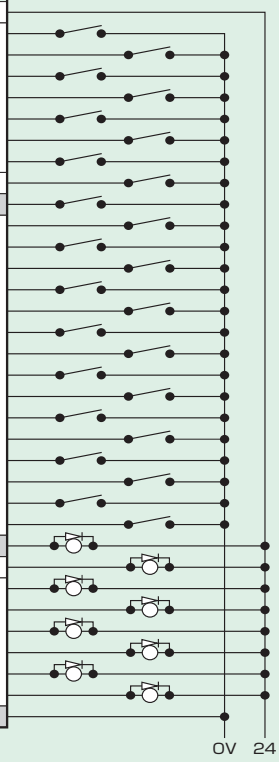

Standard Positioner Mode

PIN No.	Category	Port No.	Program mode	Function	
1A	P24		24-V input	Connect 24 V.	
1B	Input	016	Position input 10	Use one of port Nos. 007 to 019 to specify the position number corresponding to the position to move the actuator to. The value can be specified by either a BCD code or binary code.	
2A		017	Position input 11		
2B		018	Position input 12		
3A		019	Position input 13		
3B		020	Position input 14		
4A		021	Position input 15		
4B		022	Position input 16		
5A		023	Error reset		This signal resets minor errors. (To reset major errors, the power must be reconnected.)
5B		000	Start		The actuator starts moving to the position corresponding to the selected position number.
6A		001	Home return		The actuator returns home.
6B		002	Servo ON		The servo is turned ON/OFF.
7A		003	Push motion		Push-motion operation is performed.
7B		004	Pause		The actuator pauses when this signal turns OFF, and resumes operation when the signal is turned ON.
8A		005	Cancel		The actuator stops when this signal turns OFF, and the remaining operation is cancelled.
8B		006	Interpolation setting		With a 2-axis system, the axes move via linear interpolation when this signal is ON.
9A		007	Position input 1		Use one of port Nos. 007 to 019 to specify the position number corresponding to the position to move the actuator to. The value can be specified by either a BCD code or binary code.
9B	008	Position input 2			
10A	009	Position input 3			
10B	010	Position input 4			
11A	011	Position input 5			
11B	012	Position input 6			
12A	013	Position input 7			
12B	014	Position input 8			
13A	015	Position input 9			
13B	Output	300	Alarm	This signal is output when an alarm has occurred. (Contact B)	
14A		301	Ready	This signal is output when the controller has started properly and become ready.	
14B		302	Positioning complete	This signal is output when movement to the specified position is completed.	
15A		303	Home return complete	This signal is output when home return is completed.	
15B		304	Servo ON output	This signal is output while the servo is ON.	
16A		305	Push-motion complete	This signal is output when push-motion operation is completed.	
16B		306	System battery error	This signal is output when the system battery voltage has dropped (to the warning level).	
17A	307	Absolute battery error	This signal is output when the absolute battery voltage has dropped (to the warning level).		
17B	N		OV input	Connect OV.	

Wiring diagram

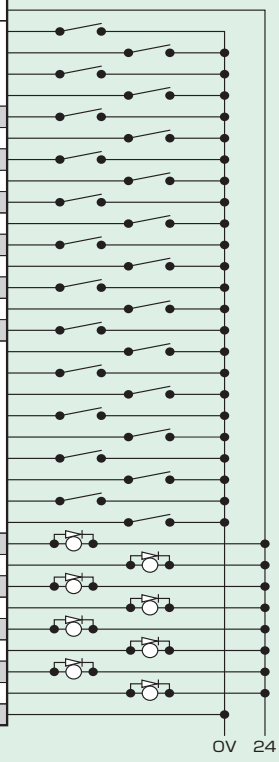

Explanation of I/O Functions

Type-switching Positioner Mode

PIN No.	Category	Port No.	Program mode	Function	
1A	P24		24-V input	Connect 24-V.	
1B		016	Position/type input 10	Use one of port Nos. 007 to 022 to specify the position number corresponding to the position to move the actuator to, and another to specify the type number. Position numbers and type numbers are assigned using parameters. The value can be specified by either a BCD code or binary code.	
2A		017	Position/type input 11		
2B		018	Position/type input 12		
3A		019	Position/type input 13		
3B		020	Position/type input 14		
4A		021	Position/type input 15		
4B		022	Position/type input 16		
5A		023	Error reset		This signal resets minor errors. (To reset major errors, the power must be reconnected.)
5B		000	Start		The actuator starts moving to the position corresponding to the selected position number.
6A		001	Home return		The actuator returns home.
6B		002	Servo ON		The servo is turned ON/OFF.
7A		003	Push motion		Push-motion operation is performed.
7B		004	Pause		The actuator pauses when this signal turns OFF, and resumes operation when the signal is turned ON.
8A		005	Cancel		The actuator stops when this signal turns OFF, and the remaining operation is cancelled.
8B		006	Interpolation setting		With a 2-axis system, the axes move via linear interpolation when this signal is ON.
9A		007	Position/type input 1		Use one of port Nos. 007 to 022 to specify the position number corresponding to the position to move the actuator to, and another to specify the type number. Position numbers and type numbers are assigned using parameters. The value can be specified by either a BCD code or binary code.
9B		008	Position/type input 2		
10A		009	Position/type input 3		
10B		010	Position/type input 4		
11A		011	Position/type input 5		
11B		012	Position/type input 6		
12A		013	Position/type input 7		
12B		014	Position/type input 8		
13A		015	Position/type input 9		
13B		300	Alarm	This signal is output when an alarm has occurred. (Contact B)	
14A		301	Ready	This signal is output when the controller has started properly and become ready.	
14B		302	Positioning complete	This signal is output when movement to the specified position is completed.	
15A		303	Home return complete	This signal is output when home return is completed.	
15B		304	Servo ON output	This signal is output while the servo is ON.	
16A		305	Push-motion complete	This signal is output when push-motion operation is completed.	
16B		306	System battery error	This signal is output when the system battery voltage has dropped (to the warning level).	
17A		307	Absolute battery error	This signal is output when the absolute battery voltage has dropped (to the warning level).	
17B	N		OV input	Connect OV.	

Wiring diagram

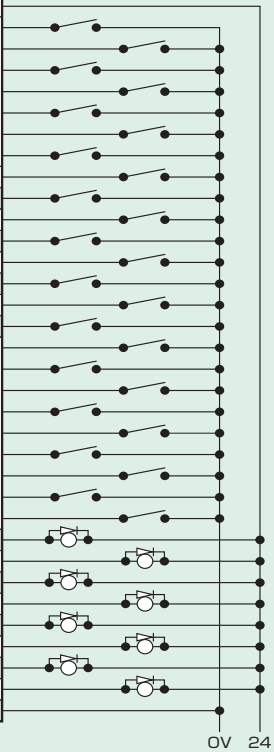

2-axis Independent Positioner Mode

PIN No.	Category	Port No.	Program mode	Function	
1A	P24		24-V input	Connect 24-V.	
1B		016	Position/type input 7	Use any of port Nos. 010 to 022 to specify the position number corresponding to the position to move the actuator to. Assignment of position numbers for axes 1 and 2 is set using parameters. The value can be specified by either a BCD code or binary code.	
2A		017	Position/type input 8		
2B		018	Position/type input 9		
3A		019	Position/type input 10		
3B		020	Position/type input 11		
4A		021	Position/type input 12		
4B		022	Position/type input 13		
5A		023	Error reset		This signal resets minor errors. (To reset major errors, the power must be reconnected.)
5B		000	Start 1		Axis 1 starts moving to the position corresponding to the selected position number.
6A		001	Home return 1		Axis 1 returns home.
6B		002	Servo ON 1		The servo of axis 1 is turned ON/OFF.
7A		003	Pause 1		Axis 1 pauses when this signal turns OFF, and resumes the remaining operation when the signal turns ON.
7B		004	Cancel 1		The movement of axis 2 is cancelled.
8A		005	Start 2		Axis 2 starts moving to the position corresponding to the selected position number.
8B		006	Home return 2		Axis 2 returns home.
9A		007	Servo ON 2		The servo of axis 2 is turned ON/OFF.
9B		008	Pause 2	Axis 2 pauses when this signal turns OFF, and resumes the remaining operation when the signal turns ON.	
10A		009	Cancel 2	The movement of axis 2 is cancelled.	
10B		010	Position input 1	Use any of port Nos. 010 to 022 to specify the position number corresponding to the position to move the actuator to. Assignment of position numbers for axes 1 and 2 is set using parameters. The value can be specified by either a BCD code or binary code.	
11A		011	Position input 2		
11B		012	Position input 3		
12A		013	Position input 4		
12B		014	Position input 5		
13A		015	Position input 6		
13B		300	Alarm	This signal is output when an alarm has occurred. (Contact B)	
14A		301	Ready	This signal is output when the controller has started properly and become ready.	
14B		302	Positioning complete 1	This signal is output when axis 1 completes its movement to the specified position.	
15A		303	Home return complete 1	This signal is output when axis 1 completes its home return.	
15B		304	Servo ON output 1	This signal is output while the servo of axis 1 is ON.	
16A		305	Positioning complete 2	This signal is output when axis 2 completes its movement to the specified position.	
16B		306	Home return complete 2	This signal is output when axis 2 completes its home return.	
17A		307	Servo ON output 2	This signal is output while the servo of axis 2 is ON.	
17B	N		OV input	Connect OV.	

Wiring diagram

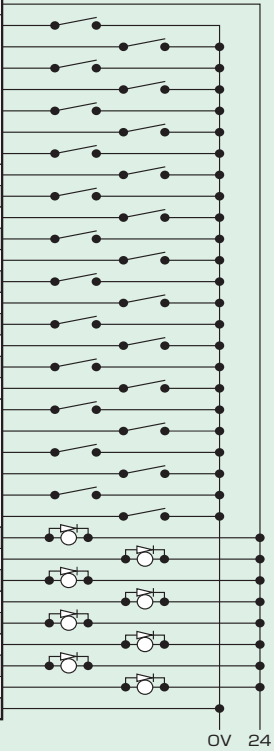

Explanation of I/O Functions

Teaching Positioner Mode

PIN No.	Category	Port No.	Program mode	Function
1A	P24		24-V input	Connect 24 V
1B		016	Axis 1 JOG -	Axis 1 moves in the negative direction while this signal is input.
2A		017	Axis 2 JOG +	Axis 2 moves in the positive direction while this signal is input.
2B		018	Axis 2 JOG -	Axis 2 moves in the negative direction while this signal is input.
3A		019	Inching specification (0.01 mm)	Specify the distance to be traveled by inching. (The travel represents the sum of values specified for port Nos. 019 to 022.)
3B		020	Inching specification (0.1 mm)	
4A		021	Inching specification (0.5 mm)	
4B		022	Inching specification (1 mm)	
5A		023	Error reset	This signal resets minor errors. (To reset major errors, the power must be reconnected.)
5B		000	Start	The actuator starts moving to the position corresponding to the selected position number.
6A		001	Servo ON	The servo is turned ON/OFF.
6B		002	Pause	The actuator pauses when this signal turns OFF, and resumes operation when the signal is turned ON.
7A	Input	003	Position/type input 1	Use any of port Nos. 003 to 013 to specify the position number corresponding to the position to move the actuator to, and another to specify the position number under which to input the current position. When port No. 014 for teaching mode specification is ON, turning ON port No. 000 for start signal writes the current value to the specified position number.
7B		004	Position/type input 2	
8A		005	Position/type input 3	
8B		006	Position/type input 4	
9A		007	Position/type input 5	
9B		008	Position/type input 6	
10A		009	Position/type input 7	
10B		010	Position/type input 8	
11A		011	Position/type input 9	
11B		012	Position/type input 10	
12A		013	Position/type input 11	
12B	014	Teaching mode specification		
13A		015	Axis 1 JOG +	Axis 1 moves in the positive direction while this signal is input.
13B		300	Alarm	This signal is output when an alarm has occurred. (Contact B)
14A		301	Ready	This signal is output when the controller has started properly and become ready.
14B		302	Positioning complete	This signal is output when movement to the specified position is completed.
15A	Output	303	Home return complete	This signal is output when home return is completed.
15B		304	Servo ON output	Servo ON output
16A		305	-	-
16B		306	System battery error	This signal is output when the system battery voltage has dropped (to the warning level).
17A		307	Absolute battery error	This signal is output when the absolute battery voltage has dropped (to the warning level).
17B	N		OV input	Connect OV.

Wiring diagram

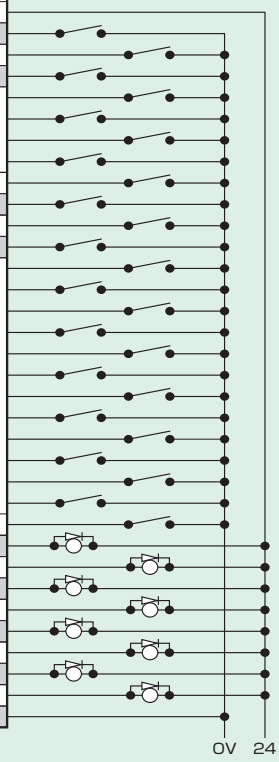

OV 24

DS-S-C1 Compatible Positioner Mode

PIN No.	Category	Port No.	Program mode	Function
1A	P24		24-V input	Connect 24 V.
1B		016	Position No. 1000	(Same with port No. 004 to 015)
2A		017	Position No. 2000	-
2B		018	Position No. 4000	-
3A		019	Position No. 8000	-
3B		020	Position No. 10000	-
4A		021	Position No. 20000	-
4B		022	NC (*1)	-
5A		023	CPU reset	The system is reset and enters the same state achieved when the power has been turned off and then turned back on.
5B		000	Start	The actuator starts moving to the position corresponding to the selected position.
6A		001	Hold (pause)	The actuator pauses when the moving signal turns ON and resumes operation when the signal is turned OFF.
6B		002	Cancel	The actuator stops when the moving signal turns ON, and the remaining operation is cancelled.
7A	Input	003	Interpolation setting	Use any of port Nos. 004 to 016 to specify the position number corresponding to the position to move the actuator to. The value is specified by a BCD code.
7B		004	Position No. 1	
8A		005	Position No. 2	
8B		006	Position No. 4	
9A		007	Position No. 8	
9B		008	Position No. 10	
10A		009	Position No. 20	
10B		010	Position No. 40	
11A		011	Position No. 80	
11B		012	Position No. 100	
12A		013	Position No. 200	
12B	014	Position No. 400		
13A		015	Position No. 800	
13B		300	Alarm	This signal is output when an alarm has occurred. (Contact B)
14A		301	Ready	This signal is output when the controller has started properly and become ready.
14B		302	Positioning complete	This signal is output when movement to the specified position is completed.
15A	Output	303	-	-
15B		304	-	-
16A		305	-	-
16B		306	System battery error	This signal is output when the system battery voltage has dropped (to the warning level).
17A		307	Absolute battery error	This signal is output when the absolute battery voltage has dropped (to the warning level).
17B	N		OV input	Connect OV.

Wiring diagram

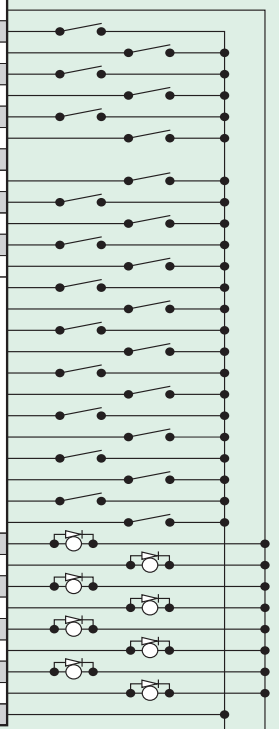

OV 24

(*1) The input must be turned OFF. Make sure this signal is not connected.

Specification Table

	Item	Specification
Base specifications	Connectable actuators Item	RCS2-series actuator, single-axis robot, linear servo actuator
	Input power supply	Single-phase 100-115 VAC ± 10% Single-phase 200-230 VAC ± 10%
	Power-supply capacity	Max. 1660 VA (400 W, based on 2-axis operation)
	Dielectric strength	500 VDC, 10 MW or more
	Withstand voltage	500 VAC, 1 minute
	Rush current	Controller 30 A / Motor 37.5 A Controller 30 A / Motor 75 A
Control specifications	Vibration resistance	XYZ directions: 10 to 57 Hz: (Single amplitude) 0.035 mm (continuous), 0.075 mm (intermittent) 58 to 150 Hz: 4.9 m/sec ² (continuous), 9.8 m/sec ² (intermittent) Controller 30 A / Motor 37.5 A
	Number of controlled axes	1 axis/2 axes Controller 30 A / Motor 37.5 A
	Maximum total output of connected axes	Connectable actuators Item Connectable actuators Item
	Position detection method	Connectable actuators Item
	Speed setting	1 mm/sec ~ (The maximum limit varies depending on the actuator.)
Program	Acceleration setting	0.01 G ~ (The maximum limit varies depending on the actuator.)
	Operation method	Program operation/positioner operation (switchable)
	Program language	Super SEL
	Number of programs	128 (※1)
	Number of program steps	9,999 (※1)
Communication	Number of multi-tasking programs	8
	Number of positioning points	2000 (※1)
	Data storage device	Flash ROM (An optional system-memory backup battery can be added.)
	Data input method	Teaching pendant or PC software
	Number of I/O points	24 input points/8 output points (NPN/PNP selectable)
General specifications	I/O power supply	24 VDC ± 10%, supplied externally
	PIO cable	CB-DS-PIO 000 (supplied with the controller)
	Serial communication function	RS232C (D-sub, half-pitch connector)/USB connector
	Field networks	(To be supported in the future)
	Protective functions	Motor overcurrent, motor/driver temperature check, overload check, encoder open check, soft limit
Surrounding air temperature/humidity	overtravel, system battery error, etc. 0 to 40°C, 10 to 95% (non-condensing)	
Surrounding ambience	Not subject to corrosive gases or significant dust.	
Protection degree	IP20	
Weight	1.4 kg	
External dimensions		100 mm (W) x 202.6 mm (H) x 126 mm (D)

(※1) PNP controllers do not support these specifications. Contact IAI for details.

External Dimensions

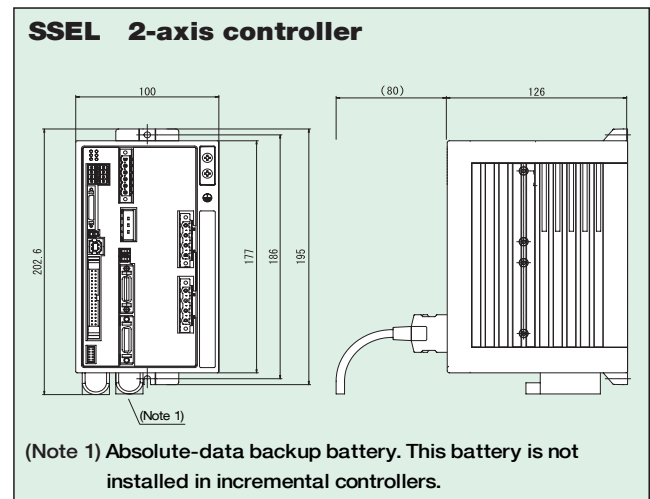
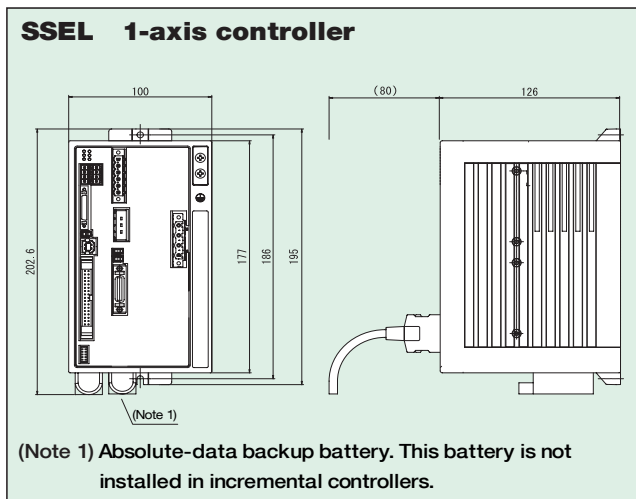

Name of Each Part

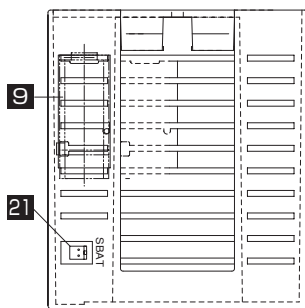
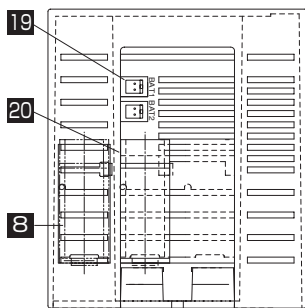
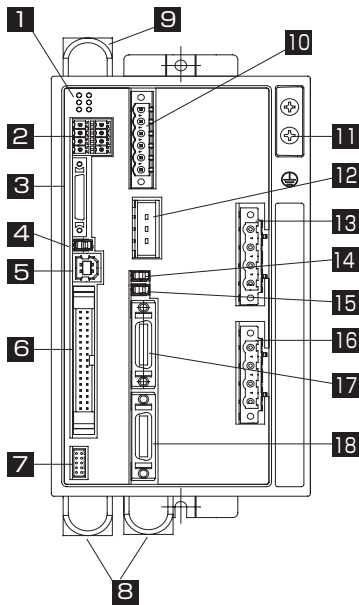

1 Status indicator LEDs

These LEDs indicate the operating condition of the controller. Each LED and what it indicates are explained below:

PWR : The controller is receiving power.

RDY : The controller is ready to perform program operation.

ALM : The controller is abnormal.

EMG : An emergency stop has been actuated and the drive source is cut off.

SV1 : The servo of actuator axis 1 is ON.

SV2 : The servo of actuator axis 2 is ON.

2 System I/O connector

This connector is used to connect the emergency stop/enable input, brake power input, etc.

3 Teaching pendant connector

This half-pitch, IO26-pin connector is used to connect the teaching pendant when the operation mode is MANU. You need a dedicated conversion cable to connect a conventional D-sub, 25-pin connector.

4 Mode switch

This switch is used to specify the operation mode of the controller. The controller is in the MANU (manual operation) mode when the switch is in the left position, or AUTO (auto operation) mode when the switch is in the right position. Teaching operation can be performed only in the MANU mode. Also note that the controller cannot perform auto operation using external I/Os in the MANU mode.

5 USB connector

This connector is used to establish USB connection with a PC. While the USB connector is in use, the TP connector cannot be used because communication via this connector is disconnected.

6 IO connector

This connector is used to connect the interface I/Os. If the DIO (24IN/8OUT) interface is specified, the I/O connector accepts a 34-pin flat cable. The I/O power is also supplied to the controller through this connector (pins 1 and 34).

7 Panel unit connector

This connector is used to connect the panel unit (optional) for displaying the controller status and error numbers.

8 Absolute-data backup battery

When an absolute axis is operated, this battery is used to retain the position data even after the power is cut off.

9 System-memory backup battery (optional)

This battery is required if you want to retain the various data stored in the built-in SRAM of the controller even after the power is cut off. This battery is optional. Order it separately if required.

10 Power-supply connector

A connector for AC power supply. The control power and motor power are input separately.

11 Grounding screw

A screw for protective grounding. Be sure to connect this screw to ground.

12 External regenerative resistor connector

This connector is used to connect an additional regenerative resistor that is connected when the built-in regenerative resistor is not enough due to high acceleration, high load, etc.

13 Axis 1 motor connector

The motor cable of actuator axis 1 is connected here.

14 Axis 2 motor connector

The motor cable of actuator axis 2 is connected here.

15 Axis 1 brake switch

This switch is used to release the axis brake. Setting the switch to the left (RLS) position forcibly releases the brake, while setting it to the right (NOM) position allows the controller to control the brake automatically.

16 Axis 2 brake switch

This switch is used to release the axis brake. Setting the switch to the left (RLS) position forcibly releases the brake, while setting it to the right (NOM) position allows the controller to control the brake automatically.

17 Axis 1 encoder connector

The encoder cable of actuator axis 1 is connected here.

18 Axis 2 encoder connector

The encoder cable of actuator axis 2 is connected here.

19 Axis 1 absolute battery connector

This connector is used to connect the absolute-data backup battery for axis 1 when the actuator is equipped with an absolute encoder.

20 Axis 2 absolute battery connector

This connector is used to connect the absolute-data backup battery for axis 2 when the actuator is equipped with an absolute encoder.

21 System-memory backup battery connector

This connector is used to connect the system-memory backup battery.

Options

Teaching Pendant

- Features A teaching device offering functions for program/position input, test operation, monitoring, and more.

■ Models/Prices

Model	Description
SEL-T-J	Standard type with connector conversion cable
SEL-TD-J	Deadman switch type with connector conversion cable

■ Configuration

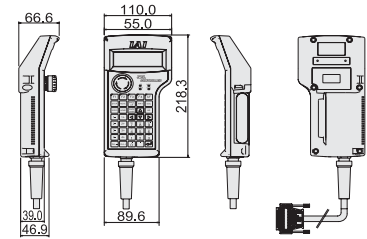
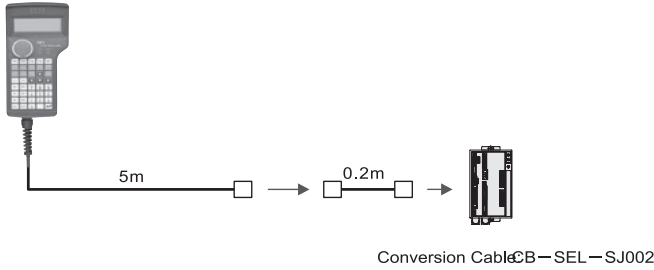

■ Specification

Item	SEL-T-J	SEL-TD-J
3-position enable switch	Not equipped	Equipped
ANSI/UL standard	Not compliant	Compliant
CE Mark	Compliant	
Display	20 characters x4 lines	
Surrounding air temp / humidity	0-40 C, 10-90% RH (non-condensing)	
Protection structure	IP54	
Weight	Approx 0.4 kg (excluding cables)	

PC Software (Windows only)

- Features A software application that assists you in the initial startup of your system by offering functions for program/position input, test operation, monitoring, and more. Enhanced debugging functions help reduce the startup time.

- Models IA-101-X-MW-J (with RS232C cable + connector conversion cable)
IA-101-X-MW (with RS232C cable + connector conversion cable)

■ Configuration

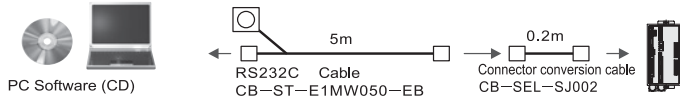

- Model IA-101-X-USB (with USB cable)

■ Configuration

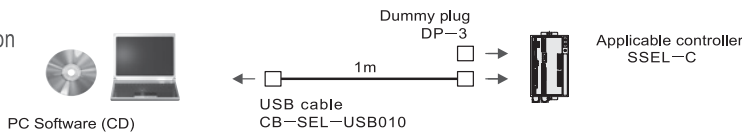

Note
SSEL controllers support only Version 6.0.0.0 or later.

Regenerative Resistor Unit

- Features A unit for converting to heat the regenerative current produced when the motor decelerates. Check the total wattage of the operated actuators in the table on the right and provide a regenerative resistor or resistors if necessary.

- Model REU-2 (for SCON/SSEL)

■ Specifications

Weight	0.9 kg
Built-in regenerative resistor	220 Ω 80 W
Unit-controller connection cable (accessory)	CB-SC-REU010 (for SSEL)

□ If two regenerative units are required, order one REU-2 and one REU-1 (refer to P. 70).

■ RRU Determination Guide

	Horizontal	Vertical
0 units	~800 W	~2 0 0
1 unit		W ~600
2 units		W ~800

□ Depending on the operating conditions, the required number of regenerative resistor(s) may become more than the applicable number shown.

■ External Dimensions

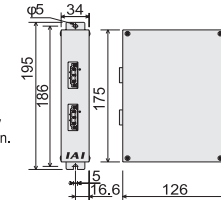

Panel Unit

- Features A display that lets you check controller error codes and the program number of the current program.

- Model REU-2

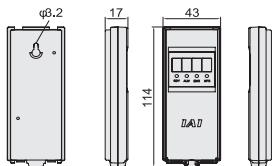

Absolute Data Backup Battery

- Features An absolute-data backup battery used when an absolute actuator is operated. The battery is the same as the system-memory backup battery.

- Model AB-5



System-memory Backup Battery

- Features This battery is required if you are using global flags, etc., in the program and want to retain the data even after the power is turned off.

- Model AB-5-CS (with case)
AB-5 (battery)



Options

Dummy Plug

- Features A plug to be connected to the teaching port to cut off the enable circuit when the SSEL controller is connected to a PC via a USB cable. (This plug is supplied with the PC software IA-101-X-USB.)
- Model DP-3



USB Cable

- Features A cable for connecting a controller with USB port to a PC. To connect a controller without USB port (XSEL) to a PC, connect the controller's RS232C cable to a USB cable via a USB conversion adapter, and connect the USB cable to the USB port on the PC. DP-3 (Refer to the PC software IA-101-X-USBMW.)
- Model CB-SEL-USB010 (cable length 1 m)



Connector Conversion Table

- Features A conversion cable for connecting the D-sub, 25-pin connector for teaching pendant/PC software to the teaching connector (half-pitch) on the SSEL controller.
- Model CB-SEL-SJ002 (cable length 0.2 m)



Replacement Parts

I/O Flat Cable

Model **CB-DS-PIO**

indicates the cable length (L). You can specify a desired length up to 10 m is supported. Example) 080 = 8 m

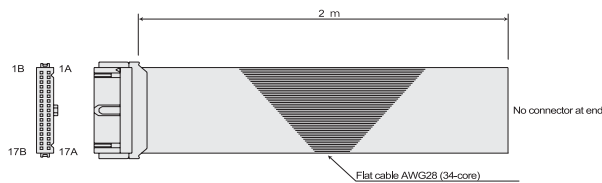

No.	Color	Wiring	No.	Color	Wiring
1A	Brown 1		9B	Gray 2	
1B	Red 1		10A	White 2	
2A	Orange 1		10B	Black 2	
2B	Yellow 1		11A	Brown-3	
3A	Green 1		11B	Red 3	
3B	Blue 1		12A	Blue 1	
4A	Purple 1		12B	Orange3	
4B	Gray 1		13A	Green 3	
5A	White 1		13B	Blue 3	
5B	Black 1		14A	Purple 3	
6A	Brown-2		14B	Gray 3	
6B	Red 2		15A	White 3	
7A	Orange 2		15B	Black 3	
7B	Yellow 2		16A	Brown-4	
8A	Green 2		16B	Red 4	
8B	Blue 2		17A	Orange 4	
9A	Purple 2		17B	Yellow 4	



X-SEL

Program controller for one to six axes



Model List/Prices

A multi-axis program controller capable of operating RCS2-series actuators. Up to six axes can be controlled simultaneously.

Type	P	Q
Name	Large-capacity type	Large-capacity type (safety category specification)
Exterior View		
Description	A large-capacity type capable of controlling up to six axes or 2400 W.	A large-capacity type conforming to safety category 4.
Max number of controlled axes	6-axes	
Number of Positions	4000 positions	
Maximum total wattage of connected axes	2400 W	
Power supply	Single-phase 200 VAC/three-phase 200 VAC	
Safety category	B	4 (with additional circuit)
Safety standards	CE	CE, ANSI
Standard price	Quoted upon request	

Explanation

[XSEL-P/Q types]

※ If you are selecting multiple options, specify them in an alphabetical order. (Example: Brake + home sensor -> BL)

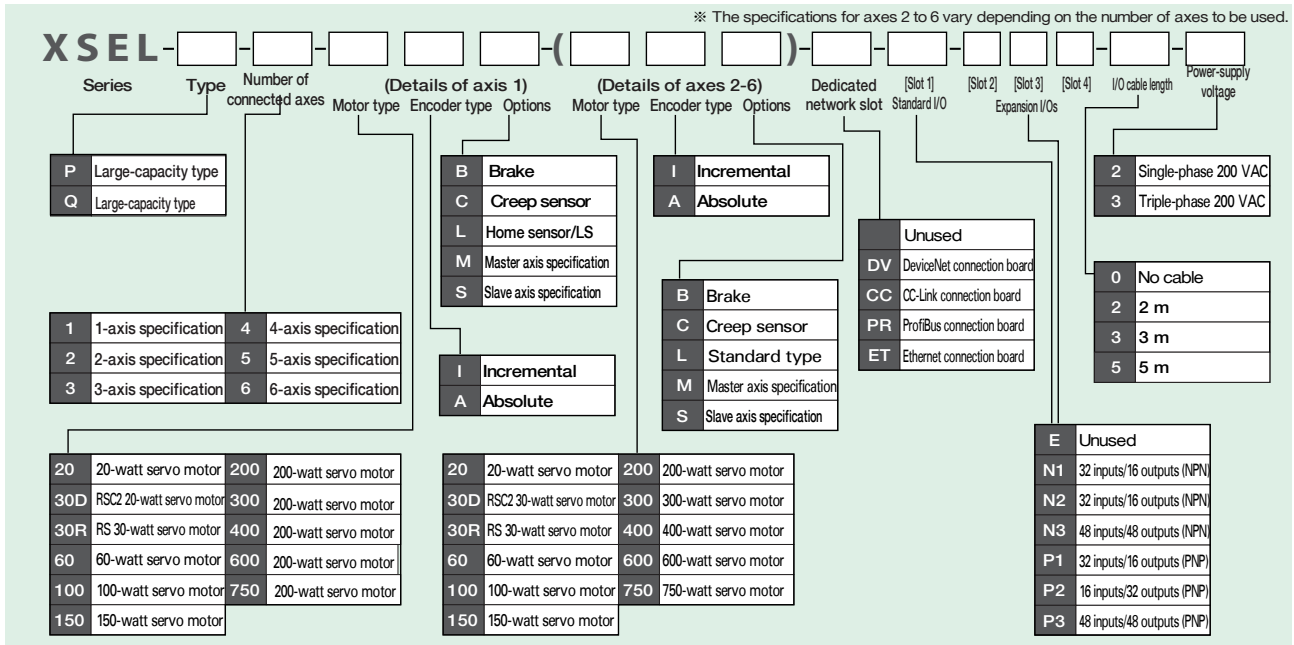

System Configuration

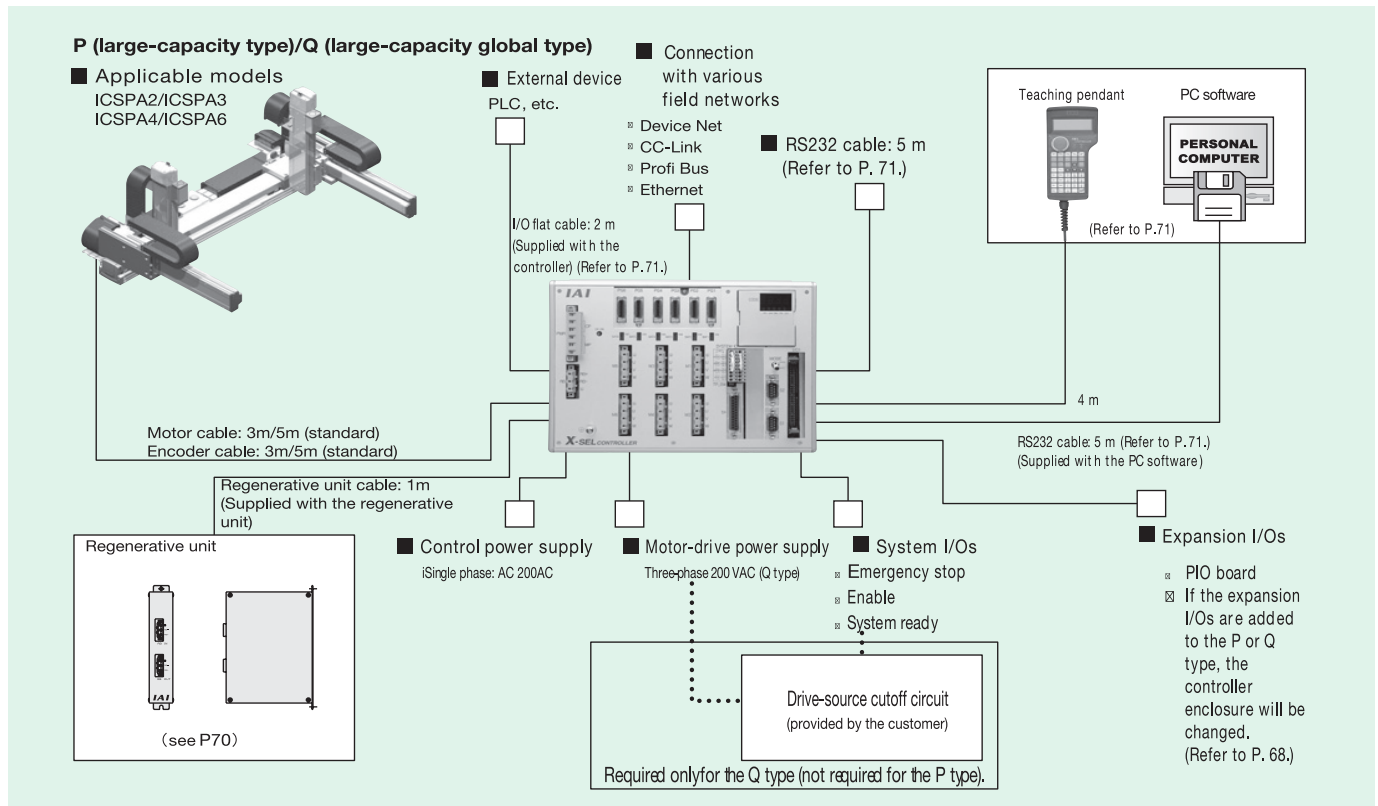

I/O Wiring

Input External Input Specification (NPN Specification)

Item	Specification
Input voltage	DC24V ±10%
Input current	7 mA per circuit
ON/OFF voltages	ON voltage- Min. 16.0 VDC / OFF voltage- Max. 5.0 VDC
Insulation method	(Photo-coder insulation)
Externally connected devices	[1] No-voltage contacts (with a minimum load of approx. 5.0 VDC/1mA) [2] Photo-electric/proximity sensors (NPN type) [3] Sequencer transistor outputs (open-collector type) [4] Sequencer contact outputs (with a minimum load of approx. 5 VDC/1mA)

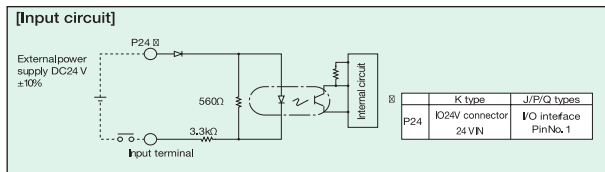

Input External Input Specification (PNP Specification)

Item	Specification
Input voltage	DC24V ±10%
Input current	7 mA per circuit
ON/OFF voltages	ON voltage- Min. 8 VDC / OFF voltage- Max. 19 VDC
Insulation method	(Photo-coder insulation)
Externally connected devices	[1] No-voltage contacts (with a minimum load of approx. 5.0 VDC/1mA) [2] Photo-electric/proximity sensors (PNP type) [3] Sequencer transistor outputs (open-collector type) [4] Sequencer contact outputs (with a minimum load of approx. 5 VDC/1mA)

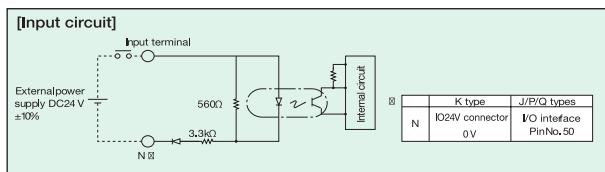

Output External Input Specification (NPN Specification)

Item	Specification
Load voltage	DC24V
Maximum load current	100 mA per point, 400 mA peak (total current)
Leak current (max.)	Max. 0.1mA per point
Insulation method	(Photo-coder insulation)
Externally connected devices	[1] Miniature relays [2] Sequencer input units

TD62084 (or equivalent) is used

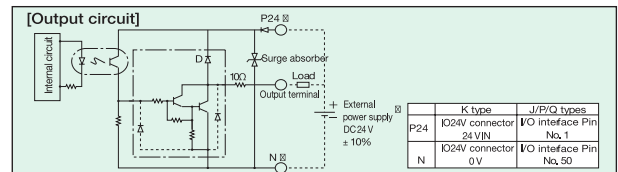

Output External Output Specification (PNP Specification)

Item	Specification
Load voltage	DC24V
Maximum load current	100 mA per point, 400 mA for 8 ports*
Leak current (max.)	Max. 0.1 mA per point
Insulation method	(Photo-coder insulation)
Externally connected devices	[1] Miniature relays [2] Sequencer input units

TD62784 (or equivalent) is used

* (Note) The maximum total load current is 400 mA for every eight ports from output port No. 300. (The maximum total load current of output port No. 300+n to 300+n+7 is 400 mA; where n is 0 or a multiple of 8.)

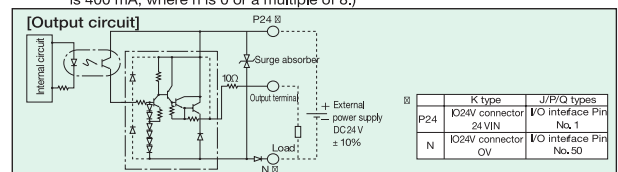

I/O Signal Tables

Standard I/O Signal Table (when N1 or P1 is selected)

Pin No.	Category	Port No.	Standard Setting
1	Input	0	(I/P/Q types: 24V connector) K type : NC
2		000	Program start
3		001	General purpose input
4		002	General purpose input
5		003	General purpose input
6		004	General purpose input
7		005	General purpose input
8		006	General purpose input
9		007	Program specification(PRG No. 1)
10		008	Program specification(PRG No. 2)
11		009	Program specification(PRG No. 4)
12		010	Program specification(PRG No. 8)
13		011	Program specification(PRG No. 1Q)
14		012	Program specification(PRG No. 2Q)
15		013	Program specification(PRG No. 4Q)
16		014	General purpose input
17		015	General purpose input
18		016	General purpose input
19		017	General purpose input
20		018	General purpose input
21		019	General purpose input
22		020	General purpose input
23		021	General purpose input
24		022	General purpose input
25		023	General purpose input
26		024	General purpose input
27		025	General purpose input
28		026	General purpose input
29		027	General purpose input
30		028	General purpose input
31		029	General purpose input
32	030	General purpose input	
33	031	General purpose input	
34	300	Alarm output	
35	301	Ready output	
36	302	Emergency stop output	
37	303	General purpose output	
38	304	General purpose output	
39	305	General purpose output	
40	306	General purpose output	
41	307	General purpose output	
42	308	General purpose output	
43	309	General purpose output	
44	310	General purpose output	
45	311	General purpose output	
46	312	General purpose output	
47	313	General purpose output	
48	314	General purpose output	
49	315	General purpose output	
50	0	(I/P/Q types: 0V connector) K type : NC	

Expansion I/O Signal Table (when N1 or P1 is selected)

Pin No.	Category	Standard Setting
1	Input	(I/P/Q types: 24V connector) K type : NC
2		General purpose input
3		General purpose input
4		General purpose input
5		General purpose input
6		General purpose input
7		General purpose input
8		General purpose input
9		General purpose input
10		General purpose input
11		General purpose input
12		General purpose input
13		General purpose input
14		General purpose input
15		General purpose input
16		General purpose input
17		General purpose input
18		General purpose input
19		General purpose input
20		General purpose input
21		General purpose input
22		General purpose input
23		General purpose input
24		General purpose input
25		General purpose input
26		General purpose input
27		General purpose input
28		General purpose input
29		General purpose input
30		General purpose input
31		General purpose input
32	General purpose input	
33	General purpose input	
34	General purpose output	
35	General purpose output	
36	General purpose output	
37	General purpose output	
38	General purpose output	
39	General purpose output	
40	General purpose output	
41	General purpose output	
42	General purpose output	
43	General purpose output	
44	General purpose output	
45	General purpose output	
46	General purpose output	
47	General purpose output	
48	General purpose output	
49	General purpose output	
50	(I/P/Q types: 0V connector) K type : NC	

Expansion I/O Signal Table (when N1 or P1 is selected)

Pin No.	Category	Standard Setting
1	Input	(I/P/Q types: 24V connector) K type : NC
2		General purpose input
3		General purpose input
4		General purpose input
5		General purpose input
6		General purpose input
7		General purpose input
8		General purpose input
9		General purpose input
10		General purpose input
11		General purpose input
12		General purpose input
13		General purpose input
14		General purpose input
15		General purpose input
16		General purpose input
17		General purpose input
18		General purpose output
19		General purpose output
20		General purpose output
21		General purpose output
22		General purpose output
23		General purpose output
24		General purpose output
25		General purpose output
26		General purpose output
27		General purpose output
28		General purpose output
29		General purpose output
30		General purpose output
31		General purpose output
32	General purpose output	
33	General purpose output	
34	Output	General purpose output
35		General purpose output
36		General purpose output
37		General purpose output
38		General purpose output
39		General purpose output
40		General purpose output
41		General purpose output
42		General purpose output
43		General purpose output
44		General purpose output
45		General purpose output
46		General purpose output
47		General purpose output
48		General purpose output
49		General purpose output
50	(I/P/Q types: 0V connector) K type : NC	

I/O Wiring

P (Large-capacity Type) / Q (Large-capacity Type Conforming to Safety Category)

Item	Description												
	P (Standard) Type							Q (Global) Type					
Controller series/type	RCS2/ISA/ISPA/ISP/ISDA/ISDACR/ISPDACR/IF/FS/RS/LSA												
Connectable actuators	20/30/60/100/150/200/300/400/600/750												
Applicable motor output	Max. 2400W (1600 W for single-phase, 200-VAC specification)												
Number of controlled axes	1 axis	2 axes	3 axes	4 axes	5 axes	6 axes	1 axis	2 axes	3 axes	4 axes	5 axes	6 axes	
Maximum output of connected axes	20Q/230 VAC, single-axis -15%, +10%												
Controller power input	20Q/230 VAC, single-axis/three-axis -10%, +10%						20Q/230 VAC, single-axis/three-axis -10%, +10%						
Motor power input	50/60 Hz												
Power-supply frequency	10MΩ or more (@ 500 VDC, measured between the power-supply terminal and each I/O terminal and between all external terminals and the case)												
Insulation resistance	1500 VAC (1 minute)						1500 VAC (1 minute)						
Withstand voltage	Max	Max	Max	Max	Max	Max	Max	Max	Max	Max	Max	Max	
Power-supply capacity	1744VA	3266VA	4787VA	4878VA	4931VA	4998VA	1744VA	3266VA	4787VA	4878VA	4931VA	4998VA	
Position detection method	Incremental encoder (wire-saving type) Multi-rotational data backup absolute encoder (wire-saving type)												
Complete circuit structure	Redundancy not supported						Redundancy supported						
Drive-source cutoff method	Internal relay cutoff						External safety circuit						
Enable input	Contact B input (Internal power-supply type)						Contact B input (External power-supply type, redundant)						
Speed setting	1mm/sec ~ Maximum setting varies depending on the actuator's specifications												
Acceleration/Deceleration setting	0.01G ~ Maximum setting varies depending on the actuator's specifications												
Program language	Super SEL Language												
Number of programs	64												
Number of program steps	6,000 steps (total)												
Number of multitask programs	16												
Number of positions	4,000 positions (total)												
Data storage device	FLASH ROM + SRAM battery backup												
Data input method	Teaching pendant or PC												
Standard I/Os	I/O 48 points PIO board (NPN/PNP), I/O 96 points PIO board (NPN/PNP) - 1 board can be installed												
Expansion I/Os	I/O 48 points PIO board (NPN/PNP), I/O 96 points PIO board (NPN/PNP) - Up to 3 boards can be installed												
Serial communication function	Teaching port (D-sub 25-pin.) + 2chRS232C port (D-sub 9-pin x 2) - Standard equipment												
Protective functions	Motor overcurrent, overload, motor-driver temperature check, overload check, encoder-open detection, soft limit over, system error, battery error, etc.												
Operating environment	Temperature: 0 ~ 40C, Humidity: 30~80%, Not subject to corrosive gasses or significant dust												
Weight	5.2kg				5.7kg			4.5kg			5 kg		
Accessory	I/O flat cable												

* 1 Based on the maximum wattage of each connected axis.
* 2 Including the absolute battery, brake mechanism and expansion I/O box.

External Dimensions

■ P (Large-capacity Standard Type)/Q (Large-capacity Global Type)

With the XSEL-P/Q types, the shape and dimensions vary according to the controller specifications (encoder type, with/without brake, and with/without I/O expansion).

The four shapes shown below are available. Check the applicable dimensions based on the desired type and number of axes.

		Base shape (incremental specification)	With brake/ absolute unit	With I/O expansion base	With brake/absolute unit + I/O expansion base	Side view
Controller specifications	Encoder	Incremental	Absolute	Incremental	Absolute	
	Brake	Not equipped	Equipped	Not equipped	Equipped	
	I/O	Standard only	Standard only	Standard + expansion	Standard + expansion	
P type (large capacity)	1 to 4-axis specification					
	5 to 6-axis specification					
Q type (large capacity) (conforming to safety category)	1 to 4-axis specification					
	5 to 6-axis specification					

※Controllers of single-phase, 200-VAC specification conform to the P type dimensions.

Name of Each Part

P type (standard, 4-axis)

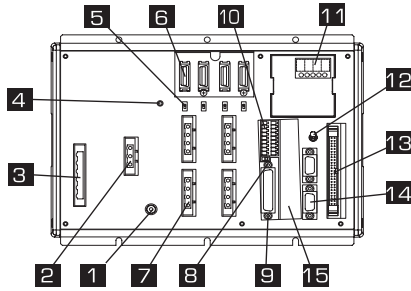

PQ type (with absolute brake unit + expansion base, 6-axis)

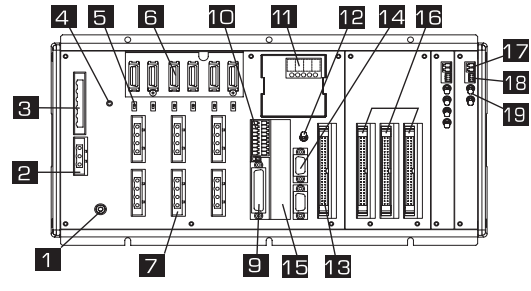

1 FG connection terminal

A connection end for connecting the FG terminal of the enclosure. The PE terminal of the AC input part is connected to the enclosure inside the controller.

2 External regenerative unit connector

This connector is used to connect an additional regenerative resistor unit that is connected when the built-in regenerative resistor is not enough due to high acceleration, high load, etc. Whether or not an external regenerative resistor is required depends on the specifics of the application such as the axis configuration.

3 AC-power input connector

A 200-VAC, three-phase input connector. This connector has six terminals including the motor/control power terminals and PE terminal. The standard specification only comes with a terminal block.

Note To prevent electric shock, do not touch this connector while the power is supplied.

4 Control-power monitor LEDA

A green light is lit when the control power supply is generating the internal controller power properly.

5 Absolute-battery enable/disable switch

A switch to enable/disable the encoder backup operation using the absolute battery. The factory setting is to disable the backup operation. After connecting the encoder/axis-sensor cables, turn on the power and then set the switch to the top position.

6 Encoder/axis-sensor connector

This connector is used to connect the actuator encoder and axis sensors such as LS, CREEP and OT. *: LS, CREEP and OT sensors are optional.

7 Motor connector

A connector for driving the motor in the actuator.

8 Teaching-pendant type selector switch

This switch is used to change the type of the teaching pendant to be connected to the teaching connector **9**. You can switch between IAI's standard teaching pendant and ANSI teaching pendant. Set the switch on the front side of the board according to the teaching pendant you are using.

9 Teaching connector

This teaching interface is used to connect IAI's teaching pendant or a PC (PC software) to operate, set or otherwise manipulate your system.

10 System I/O connector

This I/O connector controls the safety operations of the controller. For controllers of global specification, a safety circuit meeting up to safety category 4 can be configured using this connector together with an external safety circuit.

11 Panel window

This window consists of a 4-line, 7-segment LED display and five LED lamps, all indicating the status of your system.

Meanings of five LEDs

Name	Status when LED is lit
RDY	The CPU is ready (to perform program operation).
ALM	A CPU alarm (system-shutdown level error) or CPU hardware error is present.
EMG	An emergency stop has been actuated or a CPU or power-supply hardware error is present.
PSE	A power-supply hardware error is present.
CLK	The system clock is abnormal.

12 Mode switch

This alternate switch with lock is used to indicate the operation mode of the controller. To operate this switch, pull the switch toward you and then tilt it to a desired position. The top position corresponds to the MANU (manual) mode, while the bottom position corresponds to the AUTO (auto) mode. Teaching operation can be performed only in the MANU mode. Also note that auto program start is not supported in the MANU mode.

13 Standard I/O connector

This alternate switch with lock is used to indicate the operation mode of the controller. To operate this switch, pull the switch toward you and then tilt it to a desired position. The top position corresponds to the MANU (manual) mode, while the bottom position corresponds to the AUTO (auto) mode. Teaching operation can be performed only in the MANU mode. Also note that auto program start is not supported in the MANU mode.

Item	Description
Connector name	I/O
Applicable connector	Flat connector, 50-pin
Power supply	Power is supplied from connector pin Nos. 1 and 50.
Inputs	32 points (including general-purpose and dedicated inputs).
Outputs	16 points (including general-purpose and dedicated outputs).
Connected to	External PLC, sensor, etc.

14 General-purpose RS232C port connector

A port to connect general-purpose RS232C devices (two channels are available).

15 Field-network board slot

Install a field-pass interface module in this slot.

16 Expansion I/O board (optional)

Install an optional expansion I/O board in this slot.

17 Brake-power input connector

A power input connector for driving the brake in the actuator. 24 VDC must be supplied externally. If the specified power is not supplied, the actuator brake cannot be released. Be sure to supply the brake power for axes with brake. Use a shielded cable for the brake power cable and connect the shield on the 24-V power supply side.

18 Brake-release switch connector

This connector is used to connect a switch for releasing the actuator brake from outside the controller. The brake can be released by shorting the COM terminal and BKMRL* terminal of this connector. Use this connector if you want to operate the actuator manually when the controller power has been cut off or any other error is present.

19 Brake switch

This alternate switch with lock is used to release the axis brake. To operate this switch, pull the switch toward you and then tilt it to a desired position. The brake is forcibly released when the switch is in the top (RLS) position, or controlled automatically by the controller when the switch is in the bottom (NOM) position.

Options

■ Regenerative Resistor Unit

Model **REU-1**

Description

A unit for converting to heat the regenerative current produced when the motor decelerates. Although the controller has a built-in regenerator resistor, an additional regenerative unit or units may be required if a large load that cannot be handled by the built-in regenerative resistor is received from the vertical axis(es).

Specification

Item	Specification
Dimensions	W 34 mm×H 195 mm× D 126 mm
Weight	0.9 kg
Built-in regenerative resistor	220Ω 80 W
Accessory	Controller connection cable (model: CB-ST-REU010), 1 m

Installation Standards Determine whether or not to install a regenerative resistor unit, and how many, if required, according to the total motor capacity of the connected vertical axes.

Horizontal Application

Motor Wattage	P/Q Type	J Type	K Type
~200 W	Not necessary	Not necessary	Not necessary
~800 W	1 unit	Not necessary	Not necessary
~1000 W	1 unit	—	Not necessary
~1500 W	2 units	—	Not necessary
~2000 W	3 units	—	—
~2400 W	4 units	—	—

Vertical Application

Motor Wattage	P/Q Type	J Type	K Type
~100 W	Not necessary	Not necessary	Not necessary
~200 W	1 unit	Not necessary	Not necessary
~400 W	1 unit	1 unit	Not necessary
~800 W	1 unit	1 unit	1 unit
~800 W	1 unit	2 units	1 unit
~1200 W	2 units	—	2 units
~1600 W	3 units	—	Contact IAI for details
~2000 W	4 units	—	—
~2400 W	5 units	—	—

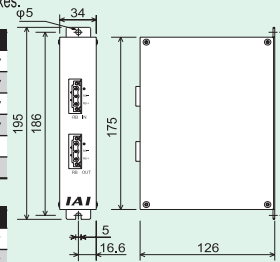

■ Absolute-data Backup Battery (for XSEL-J/K/KE/KT/KET)

Model **IA-XAB-BT**

Features A data backup battery for absolute actuators. Replace the battery as soon as the controller generates a battery alarm.

Packing Configuration Individually packed. (One battery is required for one axis. Specify the correct quantity that covers all of the axes used.)



■ Expansion SIO Board (General-purpose type)

Model / Specification IA-105-X-MW-A (RS232C connection) (board with joint cable [1] x 2)
IA-105-X-MW-A (RS232C connection) (board with joint cable [1] x 2)
IA-105-X-MW-C (RS4852C connection) (board with joint cable [2] x 1)

Description A board for serial communication with an external device. This board has two channels and supports one of three communication formats according to the supplied joint cable.

■ Absolute-data Backup Battery

Model **AB-5**

Features An absolute-data backup battery used when absolute actuators are operated.

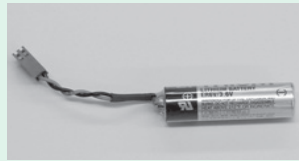

■ Expansion PIO Board

Description An optional board you can use to increase the number of I/O (input/output) points.
On general-purpose/large-capacity controllers, up to three expansion PIO boards can be installed in the expansion slots.
(On small controllers, only one expansion PIO board can be installed in the expansion slot, provided that the controller is of 3/4-axis type.)

■ DeviceNet Connection Board

A board for connecting the XSEL controller to DeviceNet.

Item	Specification														
Number of I/O points	1 board with 256 input points/256 output points * Only one board can be installed.														
Communication protocol	A certified DeviceNet 2.0 interface module is used (certification pending). Group 2 only server Insulated node of network-power operation type														
Communication specifications	Master-slave connection Bit strobe Polling Cyclic														
Baud rate	500 k/250 k/125 kbps (switchable using DIP switches)														
Communication cable	<table border="1"> <thead> <tr> <th>Baud rate</th> <th>Max. network length</th> <th>Max. branch length</th> <th>Total branch length</th> </tr> </thead> <tbody> <tr> <td>500kbps</td> <td>100m</td> <td rowspan="3">6 m</td> <td>39m</td> </tr> <tr> <td>250kbps</td> <td>250m</td> <td>78m</td> </tr> <tr> <td>125kbps</td> <td>500m</td> <td>156m</td> </tr> </tbody> </table> <p>(Note) When a thick DeviceNet cable is used.</p>	Baud rate	Max. network length	Max. branch length	Total branch length	500kbps	100m	6 m	39m	250kbps	250m	78m	125kbps	500m	156m
Baud rate	Max. network length	Max. branch length	Total branch length												
500kbps	100m	6 m	39m												
250kbps	250m		78m												
125kbps	500m		156m												
Communication power supply	24 VDC (supplied from DeviceNet)														
Current consumption	60 mA or more														
Number of occupied nodes	1 node														
Connector	MSTBA2.5/5-G.08AUM by Phoenix Contact (*1)														

(*1) The cable-end connector (SMSTB2.5/5-ST-5.08AUM) by Phoenix Contact is a standard accessory.

■ CC-Link Connection Board

A board for connecting the XSEL controller to CC-Link.

Item	Specification										
Number of I/O points	1 board with 256 input points/256 output points * Only one board can be installed.										
Communication protocol	ACC-Link Version 1.10 (certified)										
Baud rate	10M/5M/2.5M/625k/156kbps (switchable using a rotary switch)										
Communication method	Communication method										
Synchronization method	Frame synchronization method										
Encoding method	NRZI										
Transmissiorpath format	Bus type (conforming to EIA RS485)										
Transmissiorformat	Conforming to HDLC										
Error control method	CRC(X ¹⁶ +X ¹² +X ⁵ +X ¹)										
Number of occupied stations	1 to 3 stations (remoted device stations)										
Communication cable length	<table border="1"> <thead> <tr> <th>Baud rate (bps)</th> <th>10 M</th> <th>5 M</th> <th>2.5 M</th> <th>625 k</th> </tr> </thead> <tbody> <tr> <td>Cable length (m)</td> <td>100</td> <td>160</td> <td>400</td> <td>900</td> </tr> </tbody> </table>	Baud rate (bps)	10 M	5 M	2.5 M	625 k	Cable length (m)	100	160	400	900
Baud rate (bps)	10 M	5 M	2.5 M	625 k							
Cable length (m)	100	160	400	900							
Connector(controller end)	MSTBA2.5/5-G.08AUM by Phoenix Contact (*1)										

(*1) The cable-end connector (SMSTB2.5/5-ST-5.08AUM) by Phoenix Contact is a standard accessory.

Joint cable[1] Model CB-ST-232J001

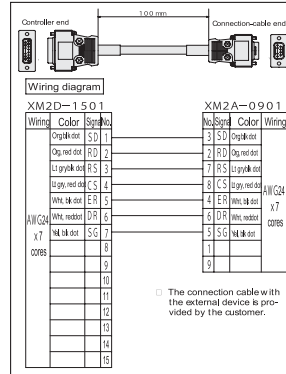

Joint cable[2] Model CB-ST-422J001

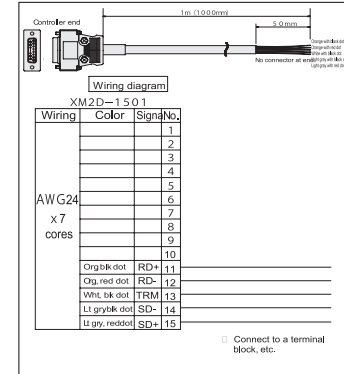

Teaching Pendant

- **Features** A teaching device offering functions for program/position input, test operation, monitoring, and more.

- **Model**

Model	Description
SEL-T	Standard Type
SEL-TD	Deadman Switch Type

Configuration

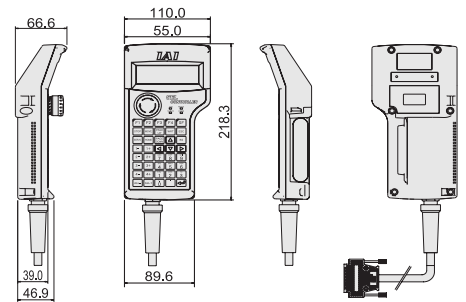
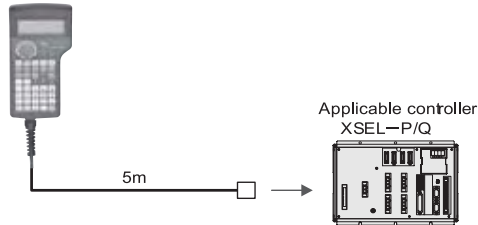

■ Specification

Item	SEL-T	SEL-TD
3-position enableswitch	Not equipped	Equipped
ANSI/UL standard	Not compliant	Compliant
CE Mark	Compliant	
Display	20 characters x4 lines	
Surrounding air temp humidity	0-40 C, 10-90% RH (non-condensing)	
Protectionstructure	IP54	
Weight	Approx 0.4 kg (excluding cables)	

PC Software (Windows only)

- **Feature** A software application that assists you in the initial startup of your system by offering functions for program/position input, test operation, monitoring, and more. Enhanced debugging functions help reduce the startup time.

- **Model** IA-101-X-MW (with RS232C cable)

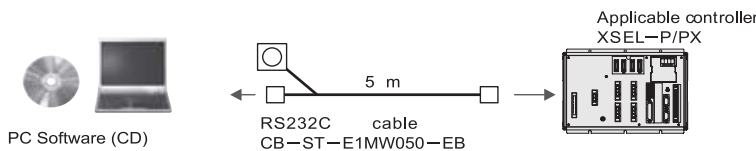

- **Model** IA-101-XA-MW (with cable conforming to safety category 4)

- **Configuration**

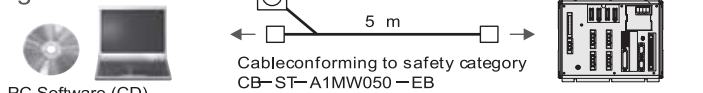

- **Model** IA-101-X-USBMW (with USB conversion adapter + cable)

- **Configuration**

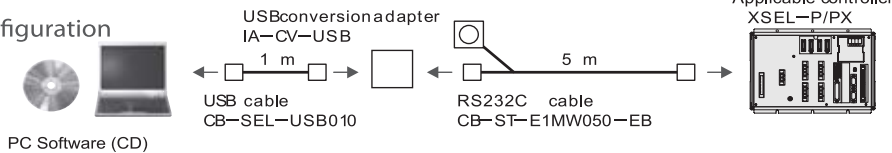

Replacement Parts

All you need a replacement cable after the purchase of your product, specify the applicable model by referring to the information below.

I/O Flat Cable (for XSEL-J/K/P/Q)

Model **CB-X-PIO** □□□

□□□ indicates the cable length (L). You can specify a desired length up to 10 m is supported. (Example) 080 = 8 m

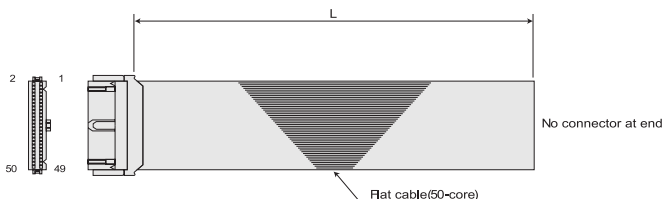

1	Brown 1	Flat cable pressure welded	18	Gray 2	Flat cable pressure welded	35	Green4	Flat cable pressure welded																																																																																												
2	Red 1		3	Orange 1		4	Yellow 1		5	Green1	6	Blue 1	7	Purple 1	8	Gray 1	9	White 1	10	Black 1	11	Brown-2	12	Red 2	13	Orange-2	14	Yellow-2	15	Green2	16	Blue2	17	Purple 2	18	Gray 2	19	Black 2	20	White 2	21	Brown-3	22	Red 3	23	Orange 3	24	Yellow 3	25	Green 3	26	Blue 3	27	Purple 3	28	Gray 3	29	Black 3	30	White 3	31	Brown-4	32	Red 4	33	Orange 4	34	Yellow 4	35	Green4	36	Blue 4	37	Purple 4	38	Gray 4	39	Black 4	40	White 4	41	Brown-5	42	Red 5	43	Orange-5	44	Yellow 5	45	Green5	46	Blue5	47	Purple 5	48	Gray 5	49	Black 5	50	White 5
3	Orange 1		4	Yellow 1		5	Green1		6	Blue 1	7	Purple 1	8	Gray 1	9	White 1	10	Black 1	11	Brown-2	12	Red 2	13	Orange-2	14	Yellow-2	15	Green2	16	Blue2	17	Purple 2	18	Gray 2	19	Black 2	20	White 2	21	Brown-3	22	Red 3	23	Orange 3	24	Yellow 3	25	Green 3	26	Blue 3	27	Purple 3	28	Gray 3	29	Black 3	30	White 3	31	Brown-4	32	Red 4	33	Orange 4	34	Yellow 4	35	Green4	36	Blue 4	37	Purple 4	38	Gray 4	39	Black 4	40	White 4	41	Brown-5	42	Red 5	43	Orange-5	44	Yellow 5	45	Green5	46	Blue5	47	Purple 5	48	Gray 5	49	Black 5	50	White 5		
4	Yellow 1		5	Green1		6	Blue 1		7	Purple 1	8	Gray 1	9	White 1	10	Black 1	11	Brown-2	12	Red 2	13	Orange-2	14	Yellow-2	15	Green2	16	Blue2	17	Purple 2	18	Gray 2	19	Black 2	20	White 2	21	Brown-3	22	Red 3	23	Orange 3	24	Yellow 3	25	Green 3	26	Blue 3	27	Purple 3	28	Gray 3	29	Black 3	30	White 3	31	Brown-4	32	Red 4	33	Orange 4	34	Yellow 4	35	Green4	36	Blue 4	37	Purple 4	38	Gray 4	39	Black 4	40	White 4	41	Brown-5	42	Red 5	43	Orange-5	44	Yellow 5	45	Green5	46	Blue5	47	Purple 5	48	Gray 5	49	Black 5	50	White 5				
5	Green1		6	Blue 1		7	Purple 1		8	Gray 1	9	White 1	10	Black 1	11	Brown-2	12	Red 2	13	Orange-2	14	Yellow-2	15	Green2	16	Blue2	17	Purple 2	18	Gray 2	19	Black 2	20	White 2	21	Brown-3	22	Red 3	23	Orange 3	24	Yellow 3	25	Green 3	26	Blue 3	27	Purple 3	28	Gray 3	29	Black 3	30	White 3	31	Brown-4	32	Red 4	33	Orange 4	34	Yellow 4	35	Green4	36	Blue 4	37	Purple 4	38	Gray 4	39	Black 4	40	White 4	41	Brown-5	42	Red 5	43	Orange-5	44	Yellow 5	45	Green5	46	Blue5	47	Purple 5	48	Gray 5	49	Black 5	50	White 5						
6	Blue 1		7	Purple 1		8	Gray 1		9	White 1	10	Black 1	11	Brown-2	12	Red 2	13	Orange-2	14	Yellow-2	15	Green2	16	Blue2	17	Purple 2	18	Gray 2	19	Black 2	20	White 2	21	Brown-3	22	Red 3	23	Orange 3	24	Yellow 3	25	Green 3	26	Blue 3	27	Purple 3	28	Gray 3	29	Black 3	30	White 3	31	Brown-4	32	Red 4	33	Orange 4	34	Yellow 4	35	Green4	36	Blue 4	37	Purple 4	38	Gray 4	39	Black 4	40	White 4	41	Brown-5	42	Red 5	43	Orange-5	44	Yellow 5	45	Green5	46	Blue5	47	Purple 5	48	Gray 5	49	Black 5	50	White 5								
7	Purple 1		8	Gray 1		9	White 1		10	Black 1	11	Brown-2	12	Red 2	13	Orange-2	14	Yellow-2	15	Green2	16	Blue2	17	Purple 2	18	Gray 2	19	Black 2	20	White 2	21	Brown-3	22	Red 3	23	Orange 3	24	Yellow 3	25	Green 3	26	Blue 3	27	Purple 3	28	Gray 3	29	Black 3	30	White 3	31	Brown-4	32	Red 4	33	Orange 4	34	Yellow 4	35	Green4	36	Blue 4	37	Purple 4	38	Gray 4	39	Black 4	40	White 4	41	Brown-5	42	Red 5	43	Orange-5	44	Yellow 5	45	Green5	46	Blue5	47	Purple 5	48	Gray 5	49	Black 5	50	White 5										
8	Gray 1		9	White 1		10	Black 1		11	Brown-2	12	Red 2	13	Orange-2	14	Yellow-2	15	Green2	16	Blue2	17	Purple 2	18	Gray 2	19	Black 2	20	White 2	21	Brown-3	22	Red 3	23	Orange 3	24	Yellow 3	25	Green 3	26	Blue 3	27	Purple 3	28	Gray 3	29	Black 3	30	White 3	31	Brown-4	32	Red 4	33	Orange 4	34	Yellow 4	35	Green4	36	Blue 4	37	Purple 4	38	Gray 4	39	Black 4	40	White 4	41	Brown-5	42	Red 5	43	Orange-5	44	Yellow 5	45	Green5	46	Blue5	47	Purple 5	48	Gray 5	49	Black 5	50	White 5												
9	White 1		10	Black 1		11	Brown-2		12	Red 2	13	Orange-2	14	Yellow-2	15	Green2	16	Blue2	17	Purple 2	18	Gray 2	19	Black 2	20	White 2	21	Brown-3	22	Red 3	23	Orange 3	24	Yellow 3	25	Green 3	26	Blue 3	27	Purple 3	28	Gray 3	29	Black 3	30	White 3	31	Brown-4	32	Red 4	33	Orange 4	34	Yellow 4	35	Green4	36	Blue 4	37	Purple 4	38	Gray 4	39	Black 4	40	White 4	41	Brown-5	42	Red 5	43	Orange-5	44	Yellow 5	45	Green5	46	Blue5	47	Purple 5	48	Gray 5	49	Black 5	50	White 5														
10	Black 1		11	Brown-2		12	Red 2		13	Orange-2	14	Yellow-2	15	Green2	16	Blue2	17	Purple 2	18	Gray 2	19	Black 2	20	White 2	21	Brown-3	22	Red 3	23	Orange 3	24	Yellow 3	25	Green 3	26	Blue 3	27	Purple 3	28	Gray 3	29	Black 3	30	White 3	31	Brown-4	32	Red 4	33	Orange 4	34	Yellow 4	35	Green4	36	Blue 4	37	Purple 4	38	Gray 4	39	Black 4	40	White 4	41	Brown-5	42	Red 5	43	Orange-5	44	Yellow 5	45	Green5	46	Blue5	47	Purple 5	48	Gray 5	49	Black 5	50	White 5																
11	Brown-2		12	Red 2		13	Orange-2		14	Yellow-2	15	Green2	16	Blue2	17	Purple 2	18	Gray 2	19	Black 2	20	White 2	21	Brown-3	22	Red 3	23	Orange 3	24	Yellow 3	25	Green 3	26	Blue 3	27	Purple 3	28	Gray 3	29	Black 3	30	White 3	31	Brown-4	32	Red 4	33	Orange 4	34	Yellow 4	35	Green4	36	Blue 4	37	Purple 4	38	Gray 4	39	Black 4	40	White 4	41	Brown-5	42	Red 5	43	Orange-5	44	Yellow 5	45	Green5	46	Blue5	47	Purple 5	48	Gray 5	49	Black 5	50	White 5																		
12	Red 2		13	Orange-2		14	Yellow-2		15	Green2	16	Blue2	17	Purple 2	18	Gray 2	19	Black 2	20	White 2	21	Brown-3	22	Red 3	23	Orange 3	24	Yellow 3	25	Green 3	26	Blue 3	27	Purple 3	28	Gray 3	29	Black 3	30	White 3	31	Brown-4	32	Red 4	33	Orange 4	34	Yellow 4	35	Green4	36	Blue 4	37	Purple 4	38	Gray 4	39	Black 4	40	White 4	41	Brown-5	42	Red 5	43	Orange-5	44	Yellow 5	45	Green5	46	Blue5	47	Purple 5	48	Gray 5	49	Black 5	50	White 5																				
13	Orange-2		14	Yellow-2		15	Green2		16	Blue2	17	Purple 2	18	Gray 2	19	Black 2	20	White 2	21	Brown-3	22	Red 3	23	Orange 3	24	Yellow 3	25	Green 3	26	Blue 3	27	Purple 3	28	Gray 3	29	Black 3	30	White 3	31	Brown-4	32	Red 4	33	Orange 4	34	Yellow 4	35	Green4	36	Blue 4	37	Purple 4	38	Gray 4	39	Black 4	40	White 4	41	Brown-5	42	Red 5	43	Orange-5	44	Yellow 5	45	Green5	46	Blue5	47	Purple 5	48	Gray 5	49	Black 5	50	White 5																						
14	Yellow-2		15	Green2		16	Blue2		17	Purple 2	18	Gray 2	19	Black 2	20	White 2	21	Brown-3	22	Red 3	23	Orange 3	24	Yellow 3	25	Green 3	26	Blue 3	27	Purple 3	28	Gray 3	29	Black 3	30	White 3	31	Brown-4	32	Red 4	33	Orange 4	34	Yellow 4	35	Green4	36	Blue 4	37	Purple 4	38	Gray 4	39	Black 4	40	White 4	41	Brown-5	42	Red 5	43	Orange-5	44	Yellow 5	45	Green5	46	Blue5	47	Purple 5	48	Gray 5	49	Black 5	50	White 5																								
15	Green2		16	Blue2		17	Purple 2		18	Gray 2	19	Black 2	20	White 2	21	Brown-3	22	Red 3	23	Orange 3	24	Yellow 3	25	Green 3	26	Blue 3	27	Purple 3	28	Gray 3	29	Black 3	30	White 3	31	Brown-4	32	Red 4	33	Orange 4	34	Yellow 4	35	Green4	36	Blue 4	37	Purple 4	38	Gray 4	39	Black 4	40	White 4	41	Brown-5	42	Red 5	43	Orange-5	44	Yellow 5	45	Green5	46	Blue5	47	Purple 5	48	Gray 5	49	Black 5	50	White 5																										
16	Blue2		17	Purple 2		18	Gray 2		19	Black 2	20	White 2	21	Brown-3	22	Red 3	23	Orange 3	24	Yellow 3	25	Green 3	26	Blue 3	27	Purple 3	28	Gray 3	29	Black 3	30	White 3	31	Brown-4	32	Red 4	33	Orange 4	34	Yellow 4	35	Green4	36	Blue 4	37	Purple 4	38	Gray 4	39	Black 4	40	White 4	41	Brown-5	42	Red 5	43	Orange-5	44	Yellow 5	45	Green5	46	Blue5	47	Purple 5	48	Gray 5	49	Black 5	50	White 5																												
17	Purple 2		18	Gray 2		19	Black 2		20	White 2	21	Brown-3	22	Red 3	23	Orange 3	24	Yellow 3	25	Green 3	26	Blue 3	27	Purple 3	28	Gray 3	29	Black 3	30	White 3	31	Brown-4	32	Red 4	33	Orange 4	34	Yellow 4	35	Green4	36	Blue 4	37	Purple 4	38	Gray 4	39	Black 4	40	White 4	41	Brown-5	42	Red 5	43	Orange-5	44	Yellow 5	45	Green5	46	Blue5	47	Purple 5	48	Gray 5	49	Black 5	50	White 5																														
18	Gray 2	19	Black 2	20	White 2	21	Brown-3	22	Red 3	23	Orange 3	24	Yellow 3	25	Green 3	26	Blue 3	27	Purple 3	28	Gray 3	29	Black 3	30	White 3	31	Brown-4	32	Red 4	33	Orange 4	34	Yellow 4	35	Green4	36	Blue 4	37	Purple 4	38	Gray 4	39	Black 4	40	White 4	41	Brown-5	42	Red 5	43	Orange-5	44	Yellow 5	45	Green5	46	Blue5	47	Purple 5	48	Gray 5	49	Black 5	50	White 5																																			
19	Black 2	20	White 2	21	Brown-3	22	Red 3	23	Orange 3	24	Yellow 3	25	Green 3	26	Blue 3	27	Purple 3	28	Gray 3	29	Black 3	30	White 3	31	Brown-4	32	Red 4	33	Orange 4	34	Yellow 4	35	Green4	36	Blue 4	37	Purple 4	38	Gray 4	39	Black 4	40	White 4	41	Brown-5	42	Red 5	43	Orange-5	44	Yellow 5	45	Green5	46	Blue5	47	Purple 5	48	Gray 5	49	Black 5	50	White 5																																					
20	White 2	21	Brown-3	22	Red 3	23	Orange 3	24	Yellow 3	25	Green 3	26	Blue 3	27	Purple 3	28	Gray 3	29	Black 3	30	White 3	31	Brown-4	32	Red 4	33	Orange 4	34	Yellow 4	35	Green4	36	Blue 4	37	Purple 4	38	Gray 4	39	Black 4	40	White 4	41	Brown-5	42	Red 5	43	Orange-5	44	Yellow 5	45	Green5	46	Blue5	47	Purple 5	48	Gray 5	49	Black 5	50	White 5																																							
21	Brown-3	22	Red 3	23	Orange 3	24	Yellow 3	25	Green 3	26	Blue 3	27	Purple 3	28	Gray 3	29	Black 3	30	White 3	31	Brown-4	32	Red 4	33	Orange 4	34	Yellow 4	35	Green4	36	Blue 4	37	Purple 4	38	Gray 4	39	Black 4	40	White 4	41	Brown-5	42	Red 5	43	Orange-5	44	Yellow 5	45	Green5	46	Blue5	47	Purple 5	48	Gray 5	49	Black 5	50	White 5																																									
22	Red 3	23	Orange 3	24	Yellow 3	25	Green 3	26	Blue 3	27	Purple 3	28	Gray 3	29	Black 3	30	White 3	31	Brown-4	32	Red 4	33	Orange 4	34	Yellow 4	35	Green4	36	Blue 4	37	Purple 4	38	Gray 4	39	Black 4	40	White 4	41	Brown-5	42	Red 5	43	Orange-5	44	Yellow 5	45	Green5	46	Blue5	47	Purple 5	48	Gray 5	49	Black 5	50	White 5																																											
23	Orange 3	24	Yellow 3	25	Green 3	26	Blue 3	27	Purple 3	28	Gray 3	29	Black 3	30	White 3	31	Brown-4	32	Red 4	33	Orange 4	34	Yellow 4	35	Green4	36	Blue 4	37	Purple 4	38	Gray 4	39	Black 4	40	White 4	41	Brown-5	42	Red 5	43	Orange-5	44	Yellow 5	45	Green5	46	Blue5	47	Purple 5	48	Gray 5	49	Black 5	50	White 5																																													
24	Yellow 3	25	Green 3	26	Blue 3	27	Purple 3	28	Gray 3	29	Black 3	30	White 3	31	Brown-4	32	Red 4	33	Orange 4	34	Yellow 4	35	Green4	36	Blue 4	37	Purple 4	38	Gray 4	39	Black 4	40	White 4	41	Brown-5	42	Red 5	43	Orange-5	44	Yellow 5	45	Green5	46	Blue5	47	Purple 5	48	Gray 5	49	Black 5	50	White 5																																															
25	Green 3	26	Blue 3	27	Purple 3	28	Gray 3	29	Black 3	30	White 3	31	Brown-4	32	Red 4	33	Orange 4	34	Yellow 4	35	Green4	36	Blue 4	37	Purple 4	38	Gray 4	39	Black 4	40	White 4	41	Brown-5	42	Red 5	43	Orange-5	44	Yellow 5	45	Green5	46	Blue5	47	Purple 5	48	Gray 5	49	Black 5	50	White 5																																																	
26	Blue 3	27	Purple 3	28	Gray 3	29	Black 3	30	White 3	31	Brown-4	32	Red 4	33	Orange 4	34	Yellow 4	35	Green4	36	Blue 4	37	Purple 4	38	Gray 4	39	Black 4	40	White 4	41	Brown-5	42	Red 5	43	Orange-5	44	Yellow 5	45	Green5	46	Blue5	47	Purple 5	48	Gray 5	49	Black 5	50	White 5																																																			
27	Purple 3	28	Gray 3	29	Black 3	30	White 3	31	Brown-4	32	Red 4	33	Orange 4	34	Yellow 4	35	Green4	36	Blue 4	37	Purple 4	38	Gray 4	39	Black 4	40	White 4	41	Brown-5	42	Red 5	43	Orange-5	44	Yellow 5	45	Green5	46	Blue5	47	Purple 5	48	Gray 5	49	Black 5	50	White 5																																																					
28	Gray 3	29	Black 3	30	White 3	31	Brown-4	32	Red 4	33	Orange 4	34	Yellow 4	35	Green4	36	Blue 4	37	Purple 4	38	Gray 4	39	Black 4	40	White 4	41	Brown-5	42	Red 5	43	Orange-5	44	Yellow 5	45	Green5	46	Blue5	47	Purple 5	48	Gray 5	49	Black 5	50	White 5																																																							
29	Black 3	30	White 3	31	Brown-4	32	Red 4	33	Orange 4	34	Yellow 4	35	Green4	36	Blue 4	37	Purple 4	38	Gray 4	39	Black 4	40	White 4	41	Brown-5	42	Red 5	43	Orange-5	44	Yellow 5	45	Green5	46	Blue5	47	Purple 5	48	Gray 5	49	Black 5	50	White 5																																																									
30	White 3	31	Brown-4	32	Red 4	33	Orange 4	34	Yellow 4	35	Green4	36	Blue 4	37	Purple 4	38	Gray 4	39	Black 4	40	White 4	41	Brown-5	42	Red 5	43	Orange-5	44	Yellow 5	45	Green5	46	Blue5	47	Purple 5	48	Gray 5	49	Black 5	50	White 5																																																											
31	Brown-4	32	Red 4	33	Orange 4	34	Yellow 4	35	Green4	36	Blue 4	37	Purple 4	38	Gray 4	39	Black 4	40	White 4	41	Brown-5	42	Red 5	43	Orange-5	44	Yellow 5	45	Green5	46	Blue5	47	Purple 5	48	Gray 5	49	Black 5	50	White 5																																																													
32	Red 4	33	Orange 4	34	Yellow 4	35	Green4	36	Blue 4	37	Purple 4	38	Gray 4	39	Black 4	40	White 4	41	Brown-5	42	Red 5	43	Orange-5	44	Yellow 5	45	Green5	46	Blue5	47	Purple 5	48	Gray 5	49	Black 5	50	White 5																																																															
33	Orange 4	34	Yellow 4	35	Green4	36	Blue 4	37	Purple 4	38	Gray 4	39	Black 4	40	White 4	41	Brown-5	42	Red 5	43	Orange-5	44	Yellow 5	45	Green5	46	Blue5	47	Purple 5	48	Gray 5	49	Black 5	50	White 5																																																																	
34	Yellow 4	35	Green4	36	Blue 4	37	Purple 4	38	Gray 4	39	Black 4	40	White 4	41	Brown-5	42	Red 5	43	Orange-5	44	Yellow 5	45	Green5	46	Blue5	47	Purple 5	48	Gray 5	49	Black 5	50	White 5																																																																			
35	Green4	36	Blue 4	37	Purple 4	38	Gray 4	39	Black 4	40	White 4	41	Brown-5	42	Red 5	43	Orange-5	44	Yellow 5	45	Green5	46	Blue5	47	Purple 5	48	Gray 5	49	Black 5	50	White 5																																																																					
36	Blue 4	37	Purple 4	38	Gray 4	39	Black 4	40	White 4	41	Brown-5	42	Red 5	43	Orange-5	44	Yellow 5	45	Green5	46	Blue5	47	Purple 5	48	Gray 5	49	Black 5	50	White 5																																																																							
37	Purple 4	38	Gray 4	39	Black 4	40	White 4	41	Brown-5	42	Red 5	43	Orange-5	44	Yellow 5	45	Green5	46	Blue5	47	Purple 5	48	Gray 5	49	Black 5	50	White 5																																																																									
38	Gray 4	39	Black 4	40	White 4	41	Brown-5	42	Red 5	43	Orange-5	44	Yellow 5	45	Green5	46	Blue5	47	Purple 5	48	Gray 5	49	Black 5	50	White 5																																																																											
39	Black 4	40	White 4	41	Brown-5	42	Red 5	43	Orange-5	44	Yellow 5	45	Green5	46	Blue5	47	Purple 5	48	Gray 5	49	Black 5	50	White 5																																																																													
40	White 4	41	Brown-5	42	Red 5	43	Orange-5	44	Yellow 5	45	Green5	46	Blue5	47	Purple 5	48	Gray 5	49	Black 5	50	White 5																																																																															
41	Brown-5	42	Red 5	43	Orange-5	44	Yellow 5	45	Green5	46	Blue5	47	Purple 5	48	Gray 5	49	Black 5	50	White 5																																																																																	
42	Red 5	43	Orange-5	44	Yellow 5	45	Green5	46	Blue5	47	Purple 5	48	Gray 5	49	Black 5	50	White 5																																																																																			
43	Orange-5	44	Yellow 5	45	Green5	46	Blue5	47	Purple 5	48	Gray 5	49	Black 5	50	White 5																																																																																					
44	Yellow 5	45	Green5	46	Blue5	47	Purple 5	48	Gray 5	49	Black 5	50	White 5																																																																																							
45	Green5	46	Blue5	47	Purple 5	48	Gray 5	49	Black 5	50	White 5																																																																																									
46	Blue5	47	Purple 5	48	Gray 5	49	Black 5	50	White 5																																																																																											
47	Purple 5	48	Gray 5	49	Black 5	50	White 5																																																																																													
48	Gray 5	49	Black 5	50	White 5																																																																																															
49	Black 5	50	White 5																																																																																																	
50	White 5																																																																																																			



IAI America, Inc.

Head Office: 2690 W. 237th Street, Torrance, CA 90505
TEL (310) 891-6015 FAX (310) 891-0815

Chicago Office: 1261 Hamilton Parkway, Itasca, IL 60143
TEL: 630-467-9900 FAX (630) 467-9912

Atlanta Office: 1220-E Kenneston Circle, Marietta, GA 30066
TEL (678) 354-9470 FAX (678) 354-9471

IAI Industrieroboter GmbH

Ober der Róth, D-65824 Schwalbach am Taunus, Germany
TEL 06196-88950 FAX 06196-889524

